



**Adam Tas Corridor Energy**

# **50kWh battery energy storage cabinet for metropolitan area network use**





## Overview

---

This 50KW/50KWH battery system includes ten LiFePO<sub>4</sub> modules, a 50KW inverter, and a smart EMS/BMS, all housed in a compact IP54 cabinet. It delivers reliable storage for peak load shaving, solar optimization, or backup support. The BATTLINK 50kWh C&I Energy Storage System optimizes energy use for businesses by reducing costs, enhancing efficiency, and ensuring reliable power. With smart monitoring, modular scalability, and multi-layer safety protection, it supports on-grid, off-grid, and microgrid applications. Engineered for commercial and industrial-grade performance, the SolaX AEILO-P50B200 is a powerful hybrid energy storage cabinet combining a 50kW inverter with 200kWh of scalable lithium iron phosphate (LFP) battery storage. Real-time remote monitoring and diagnostics via cloud platform reduce maintenance costs by 30%. 4-layer safety system (IP54 outdoor-rated cabinet, sand/dust/rain proof) with patented cooling tech.



## 50kWh battery energy storage cabinet for metropolitan area netwo

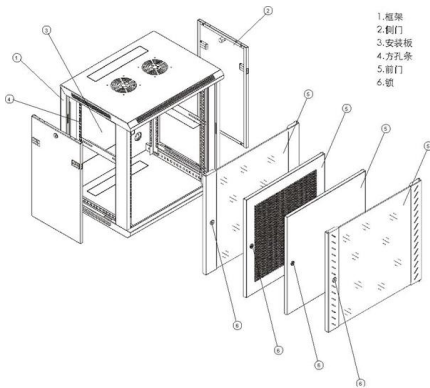

### Sunark Lithium Battery Container 30kwh 40kwh 50kwh

Sunark Lithium Battery Container 30kwh 40kwh 50kwh Hv Ess Storage System Cabinet for Industrial Use, Find Details and Price about High Voltage Cabinet Ess

### BATTLINK 50kWh C& I Energy Storage System

The BATTLINK 50kWh C& I Energy Storage System optimizes energy use for businesses by reducing costs, enhancing efficiency, and ensuring reliable power. With smart monitoring, modular scalability,



### Energy Storage Cabinet Outdoor 20KW 50KWh/ 30KW

HBOWA integrates units such as inverters, lithium battery packs, fire protection systems, and monitoring into an energy storage cabinet.



### 50kW 50kWh Compact Battery Storage Cabinet for

Product Ranges:30-50 kW / 50-100 kWh Our small commercial battery storage cabinet is designed for businesses requiring reliable backup



power and efficient



### **Commercial Industrial Energy Storage Cabinet 50kwh 100kwh 215kwh**

IP54 Cooling Liquid Cooling Product name energy storage cabinet Dimension (L\*W\*H) 1400mm\*1400mm\*2000mm Application Commercial Energy Storage System Communication Port

### **50kWh Wall-Mounted Energy Storage Battery and Sol**

Home Battery Systems 50kWh Wall-Mounted Lithium Iron Phosphate (LiFePO4) Battery: Known for its long lifespan and safety, this high-capacity, wall-mounted



### **ESS Cabinet 50kwh 100kwh 200kwh Energy Storage Battery System**

High-Efficiency Energy Storage System: The ESS Cabinet 50kwh 100kwh 200kwh energy storage battery system features a 30kw 50kw hybrid inverter PCS, ensuring efficient power support for



## TommaTech Cabinet Type 60kWh-50kW Power and Energy Storage

TommaTech Cabinet Type 60kWh-50kW Power and Energy Storage High Performance Superior performance with next generation battery technology Intelligent Management System Secure



## Industrial 50kWh Battery Storage Solution with Scalable Design

This 50KW/50KWH battery system includes ten LiFePO<sub>4</sub> modules, a 50KW inverter, and a smart EMS/BMS, all housed in a compact IP54 cabinet. It delivers reliable storage for peak load shaving,

## 50kW/100kWh Air Cooling BESS Battery Energy

Namkoo 50kW/100kWh air cooling battery energy storage system bess built-in lithium battery inverters and multi-level fire protection, quick deployment.

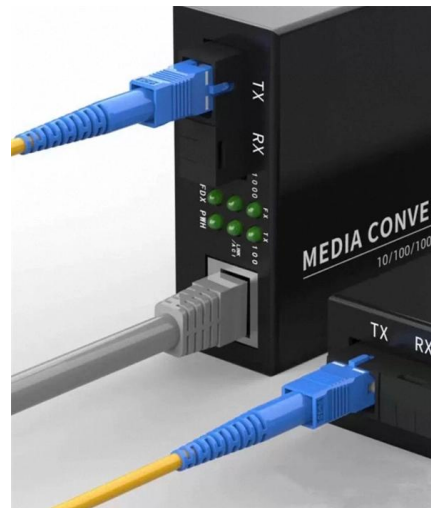

## 50kW Battery Storage Solutions: The Ultimate Guide to

50kW Battery Storage Solutions: The Ultimate Guide to Empowering Your Business In today's energy landscape, businesses are increasingly turning



### How to Design 50kW Solar Systems with 30kW 50kWh

We designed outdoor energy storage system with 51.3kW solar power and 30kW/50kWh battery capacity. Installed in container cabinets with natural



### Stacked Solar Home Energy Storage 51.2v 50Kwh Lithium Iron

Stacked Solar Home Energy Storage 51.2v 50Kwh Lithium Iron Phosphate Battery SP-SB-50KWH system Composed by 5PCS 10kWh lithium-ion battery modules that can be easily installation and

### Commercial Energy Storage Battery Cabinet

Explore high-performance energy storage battery cabinets for C& I applications. Ranging from 50KWH to 1000KWH & custom capacities. Request a price!





### **48V 5KWH-50KWH Rack mounted lithium iron**

Cabinet-type energy storage batteries are widely used in UPS to store power. With RS485 communication, you can monitor the battery status at any time and set

### **RUiXU 50kWh Lithium Battery Kit with 10 Batteries and**

Discover the RUiXU 50kWh Lithium Battery Kit featuring 10 high-capacity batteries and a sleek 10-slot cabinet for efficient energy storage.

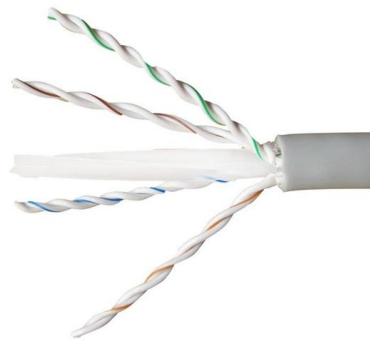

### **home energy storage 50kwh products-MNLC Green Energy**

Unlock a new level of energy autonomy with our Home Energy Storage 50kWh system, engineered to meet the substantial power demands of contemporary, all-electric homes. This robust, high-capacity

### **How to Choose the Best 50kWh Battery Storage for Home or Commercial Use**

Learn what to look for in a 50kWh battery storage system, from efficiency and lifespan to pricing and top models available in 2026.



### How to Design 50kW Solar Systems with 30kW 50kWh Energy Storage?

Discover our outdoor energy storage system with 51.3kW solar power generation and 30kW/50kWh battery capacity. Installed in container cabinets with natural cooling, it ensures stable, efficient energy



### 50kW/100kWh outdoor All-in-one Cabinet Energy

50kW/100kWh outdoor All-in-one Cabinet Energy Storage System Details SafeReliable CATL LFP battery cell Double fire suppression system design 1+1



### AEILO-P50B200 SolaX Hybrid ESS Cabinet 50kW 200kWh - Reliable

Engineered for commercial and industrial-grade performance, the SolaX AEILO-P50B200 is a powerful hybrid energy storage cabinet combining a 50kW inverter with 200kWh of scalable lithium iron

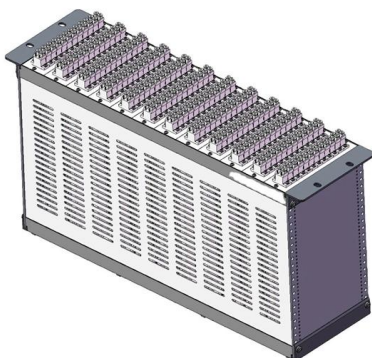



## 50 to 200kW Battery Energy Storage Systems

Discover the MEGATRON Series -- 50 to 200kW Battery Energy Storage Systems tailored for commercial and industrial applications. These systems are install

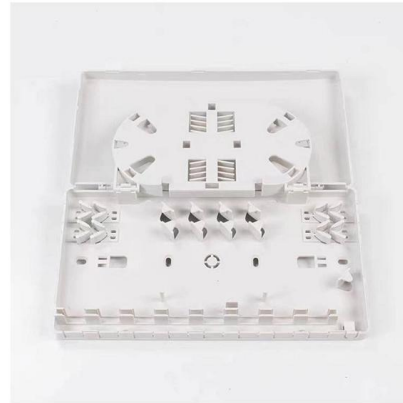

## 50kW 50kWh Compact Battery Storage Cabinet for

It offers a compact footprint, scalable capacity, and intelligent control, making it ideal for small factories, office buildings, retail stores, schools, and other commercial

## 50kW/100kWh outdoor All-in-one all-in-one cabinet

50kW/100kWh outdoor cabinet ESS solution (KAC50DP-BC100DE) is designed for small to medium size of C& I energy storage and microgrid applications.

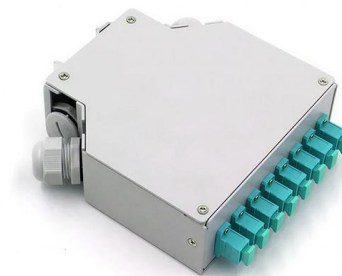

## 50kw 100kwh all in one cabinet bess battery energy

This achieves an integrated "PV + Energy Storage" solution. The cabinet system adopts a modular design, allowing flexible configurations for photovoltaic,



## Energy Storage ESS Cabinet with 50kW Lithium Battery

Equipped with advanced LFP battery technology, this 50kw lithium ion solar battery storage cabinet offers reliable power for various applications, including



## 50kwh Battery Energy Storage System

Discover a 50kWh battery energy storage system for home energy storage with LiFePO4 technology, IP54 protection, and hybrid grid connection.

## ESS Cabinet 50kwh 100kwh Energy Storage Battery

ESS Cabinet 50kwh 100kwh Energy Storage Battery System All in One 30kw 50kw Hybrid Inverter PCS for Commercial Use. Greensun, 10-year warranty, 6000



## 50KWh Lithium Battery Storage

The stackable energy storage system 50kwh has built-in BMS protection, which can manage and protect the 50kwh battery comprehensively against overcharge, over



## Contact Us

---

For datasheets, pricing, or custom telecom energy solutions, please visit:  
<https://www.koskolong.co.za>