



Adam Tas Corridor Energy

Are the cold splicing processes for PVC strip and pigtail the same





Are the cold splicing processes for PVC strip and pigtail the same



What is a Fiber Optic Pigtail, and What Is It Used For?

High-quality pigtail cables, combined with proper fusion splicing techniques, provide the highest performance for fiber optic cable terminations.

Welcome to Beltcon Industrials

Light duty P.V.C. belting Can only be spliced with the overlap method as the P.V.C. does not flow when a cold adhesive is used. Belts can be supplied already prepared, with adhesive so clients may install



pigtail connector

Discover the ultimate guide to pigtail connectors: types, applications, and best practices for electronics manufacturing. Learn more about pigtail connector solutions.

How to Splice Fiber Optic Pigtails: A Step-by-Step Guide

Master the art of fiber termination. Learn how to splice fiber optic pigtails using fusion splicing,



follow the color code, and ensure low insertion loss.



The Complete Guide to Pigtail Fibers: Simplifying

Pigtail fibers are the quiet enablers of modern connectivity, bridging devices to networks with precision and reliability. From 5G cell towers to AI data

Effects of Different Splicing Methods on Conveyor Belt

This is not a definitive assessment of splice design, but we present a suggestion for new treatment, which updates the well recognized standards of

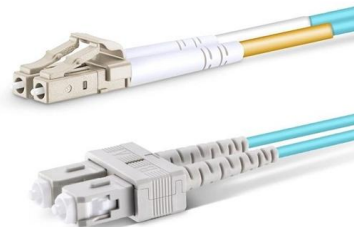

[such/ignore.txt at main · yeerma/such · GitHub](#)

aasdadasa. Contribute to yeerma/such development by creating an account on GitHub.



What is Fiber Pigtail? A Complete Guide for Beginners

A fiber pigtail is a fiber optic cable with pre-terminated fiber connector and exposed fiber. This guide introduces fiber pigtail basics, types.

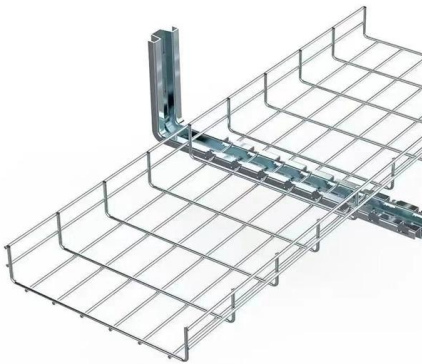

Conveyor Belt Splicing: Everything You Need to Know

This process can be achieved through either splices or vulcanization, which minimizes weak points and reduces the risk of belt failures. As a result, this

Fiber Splicing vs. Connectors

Fiber Splicing vs. Connectors: When to Use Each for Your Network In fiber optic networks, joining two fibers can be done in



Common Splicing Methods Used in Gasket Production

Once the two ends are joined together, the bond is placed in a hot mold. Cooling is required to complete the process. Cold Splicing - In this method,



The Difference Between Fiber Pigtails and Fiber Optic

While both fiber pigtailed and fiber optic cables play important roles in optical networks, they have distinct characteristics and applications. In this article,

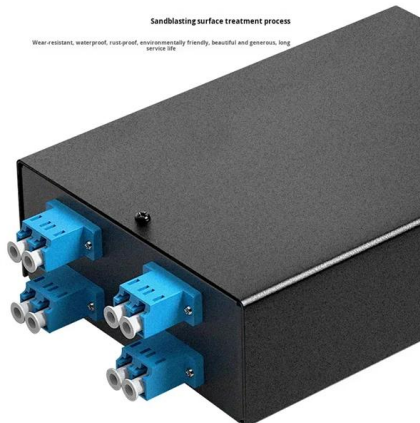

What is Fiber Pigtail? A Complete Guide for Beginners

A fiber pigtail is a thin multimode or single-mode fiber optic cable with a connector installed on one end. The purpose of the fiber pigtail is to terminate

Splicing Method and Procedure for PVC PU Conveyor Belt

One of the significant advantages of lightweight belting is the splicing versatility and excellent properties of the splices. In particular, the thermoplastic category of belts utilizes that property to allow heat





Hot, Cold, or Mechanical: How Precise Endless Splices

We recommend hot vulcanization, cold splicing, or cold bonding. In hot vulcanization, the ends of the belt are joined using heat and pressure with the

The Ultimate Guide to Pigtail Cable Assemblies and

Explore the ultimate guide to pigtail cable assemblies and connectors, covering types, applications, pricing, and available options for optimal



The Ultimate Guide to Fiber Pigtail

This blog post discusses fiber optic pigtail and provides a guide to splicing it, offering practical advice for users. TrueFiber: What is a Fiber Optic

Fiber Splicing Pigtails , Splice on Pigtails , Fiber Optic

Available in Easy Strip and 900mm tight-buffer configurations for both singlemode and multimode fiber, these pigtails are built with Corning fiber and TIA-598-A



15_SplicingTools

A cold bond splice should be kept out of use until sufficient drying time is allowed. Low heat and pressure will expedite a cold bond cure, but never exceed the maximum allowable temperature that



Common Splicing Methods Used in Gasket Production

Common Splicing Methods Used in Gasket Production Splicing is when two ends of material are joined together to create a continuous part. These



Vulcanizing Solid Woven PVC Belts Guide

This document provides instructions for vulcanizing solid woven PVC, nitrile, and neoprene conveyor belting using a finger splicing method.



Conveyor Belt Splicing Methods

Conveyor belt splicing is the process of joining together two pieces of conveyor belt. Usually, this is done to either elongate the original conveyor belt or to repair a torn or damaged conveyor belt.

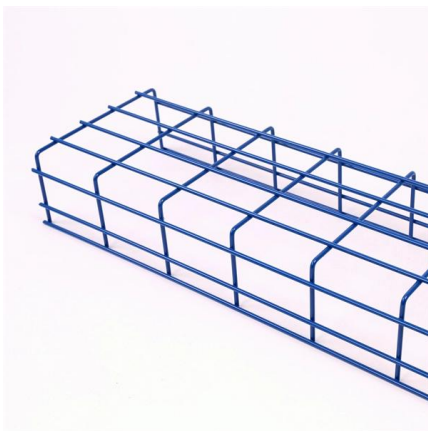

The FOA Reference For Fiber Optics

Splicing is generally used to terminate singlemode fibers by splicing preterminated pigtails onto each fiber. And of course, splicing is used for OSP restoration.

ABSTRACT

ABSTRACT This paper compares two different methods of field termination for multimode fiber: fusion spliced pigtails and pre-polished connectors. Each method has its inherent advantages and



The splice of life

The most popular method of making a splice joint is the use of vulcanized splicing, which can be either a hot or cold (glue) splice. Within this, the two most common techniques used to create a vulcanized



Contact Us

For datasheets, pricing, or custom telecom energy solutions, please visit:
<https://www.koskolong.co.za>