

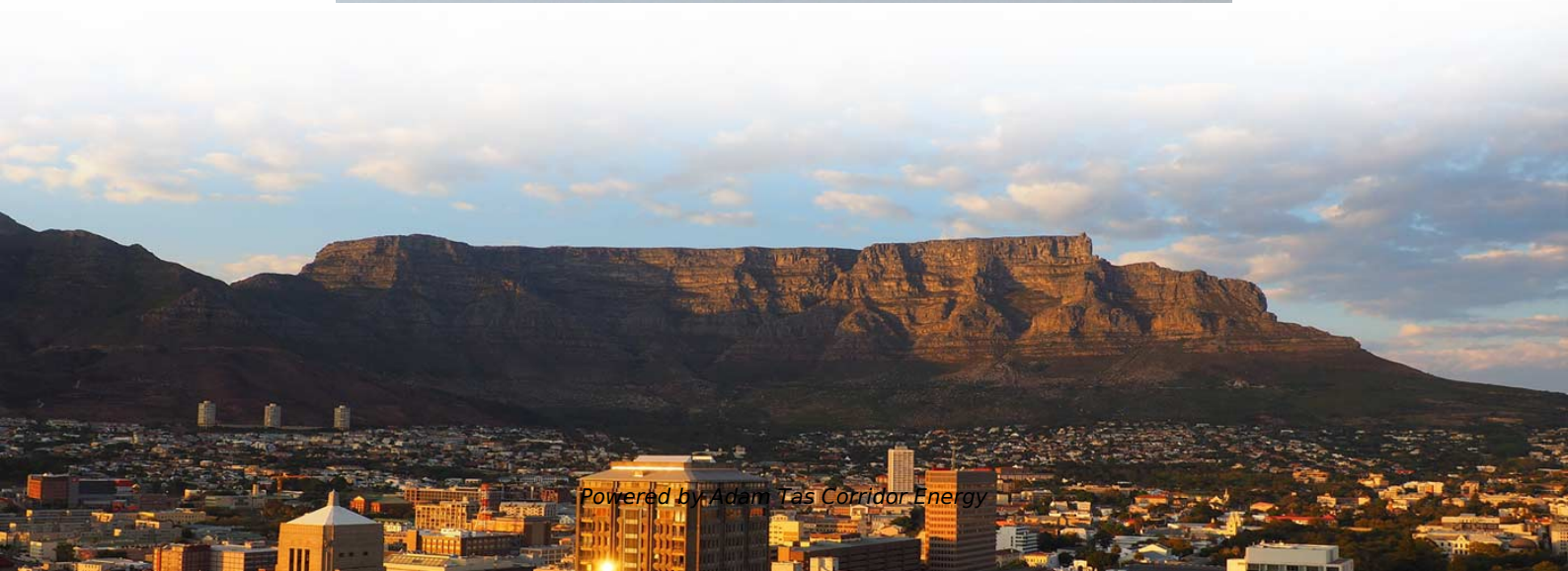

**Adam Tas Corridor Energy**

# **Circuit switch distribution box with switch**





## Circuit switch distribution box with switch

---



### Distribution Boxes, Switch Outlets and Accessories

Distribution Boxes, Switch Outlets and Accessories Our products range includes simple flush-mounted switch boxes to surface-mounted boxes for indoor use, as

### Distribution Boxes Types - The Complete Guide

However, it contains switches, breakers, circuits, and other controlling devices. Meanwhile, safely using these distribution boxes and power supplies can



### Solar Disconnect Switch Mini Circuit Breaker with IP65 Waterproof

Solar Disconnect Switch Mini Circuit Breaker with IP65 Waterproof Distribution Box PV Disconnect DC500V Photovoltaic Disconnect Solar Disconnect Switch Mini Circuit Breaker with IP65 Waterproof

### Explore Power Distribution Box Types and Functions

To put it bluntly, the distribution box is the control and distribution center of electricity.



Distribution boxes vary in shape and structure due to different



### Distribution switchboards

A distribution switchboard is the point at which an incoming-power supply divides into separate circuits, each of which is controlled and protected by the fuses or switchgear of the



### Amazon : Power Distribution Box

Browse power distribution boxes with circuit breaker protection and multiple outlet configurations. Shop durable solutions for construction and emergency use.



### Distribution Boards

Distribution boards, often referred to as electrical panels or breaker boxes, serve as the nerve center of any electrical system. Here we explore the crucial parts of a distribution board and gain insights into



## Electric Distribution Box

A distribution board (also known as panelboard, breaker panel, electric panel, DB board or DB box) is a component of an electricity supply



## Distribution Boxes, Switch Outlets and Accessories

Our products range includes simple flush-mounted switch boxes to surface-mounted boxes for indoor use, as well as high-end IP65 junction boxes for use in wet areas.

## Amazon

About this item . THQL Circuit Breaker Box, 4-Space, 125A Circuit Breaker Panels, Indoor Main Lug Load Center, No UL Approval ; NEMA 1 STEEL ENCLOSURE--Constructed of high-qualit

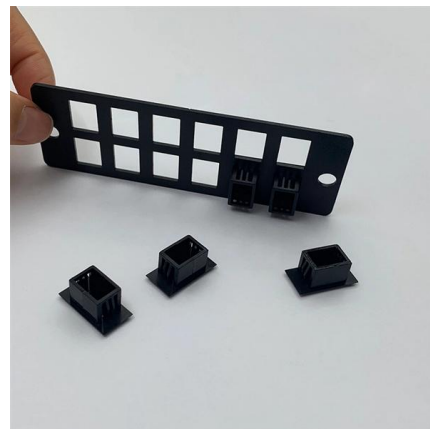

## Distribution Box Guide: Types, Components & Solutions

Understand distribution boxes (DB boxes) in 5 minutes. Learn about types, components, functions, and uses. Find the perfect DB box for your needs.



## Plug & Socket & Isolating Switch & Distribution Box

Andeli Group Co.,Ltd. - Andeli Group Co.,Ltd,founded in 1985, is located in the largest manufacturing base of low and high voltage electric equipment of Liushi

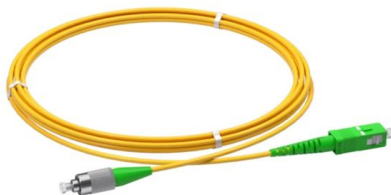
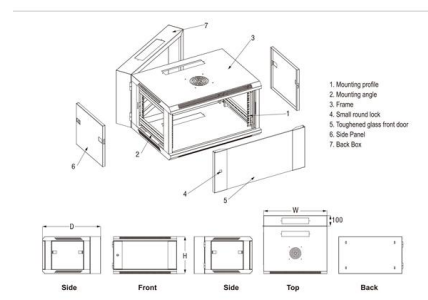

## The Ultimate Guide to Distribution Box Types

Discover the key types of distribution boxes with NUOMAK's comprehensive guide. Learn about Main Distribution Boards (MDB), Consumer Units, Transfer

## Electrical Power Distribution Box Solutions

What Is an Electrical Power Distribution Box? An electrical power distribution box, also called a distribution board or breaker panel, serves as the hub where incoming power is split into multiple





## **Circuit Protection, Fuses, Power Control & Sensing**

Littelfuse is a global manufacturer of leading technologies in circuit protection, power control & sensing. Our products are found in automotive & commercial vehicles,



## **Distribution Boxes Types - The Complete Guide**

A commonly used distribution box contains doorbells, earth leakage devices, timers, or contact breakers. However, the distribution boxes have



## **Assembly Box,electric power distribution box**

JUNON V12 series Distribution box, also known as assembly box, switch box and



## **Assembly Box,electric power distribution box**

JUNON V12 series Distribution box, also known as assembly box, switch box and distribution board, is a complete set of equipment for centralized installation of



## DISTRIBUTED PV GENERATION + ESS

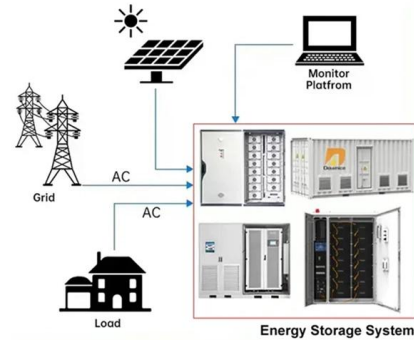

## Distribution Board vs Distribution Box: Key Differences

A distribution board is a fixed electrical panel that divides power into circuits with protection; a distribution box is more compact or portable, used for

## 12 Types of Electrical Boxes and How to Choose

Learn about the many common types of wall and ceiling electrical boxes for switches, outlets, light fixtures, ceiling fans, and junction boxes.



### Pre-Terminated Patch Panel

- Standard 19" width
- Max 144 fibers in 1U
- Ultra-High Density Ready



Dual-rail, easy install & maintain



Lightweight ABS MPO cassette



Premium sheet metal with matte coating

## Understanding Distribution Boxes: A Comprehensive Guide

In general, a distribution box is mainly used to distribute electrical power to multiple circuits and provide circuit protection. An electrical panel may



## Fuse Box Surface-Mounted Small Distributor Surface-Mounted

Safety performance: the fuse panel of the surface-mounted fuse box prevents accidental leakage and short circuits in the circuit. It has fast response time and high switching performance. IP65 Protection



## The Complete Guide to Distribution Box: Installation, Types & More

Can I add circuits to an existing distribution box? Circuit additions are possible if the distribution box has adequate capacity and available spaces. However, you must ensure the total

## Distribution Box: Types and Functions , Axis-Electricals

A distribution box ensures that electrical supply is distributed in the building, also known as a distribution board, panel board, breaker panel, or electric panel. It is



## Contact Us

---

For datasheets, pricing, or custom telecom energy solutions, please visit:  
<https://www.koskolong.co.za>