



Adam Tas Corridor Energy

Electrical distribution box before building





Electrical distribution box before building

Understanding Distribution Boxes:A Comprehensive Guide

A distribution boxes is an essential device that manages the safe and efficient flow of electrical power throughout different areas of a building or facility.

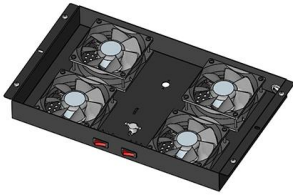

A Step-by-Step Guide to Wiring an Electrical Panel Box

An electrical panel box, also known as a breaker box or a distribution board, is a crucial component of any electrical system. It serves as a central hub for



Product Wiring Diagram

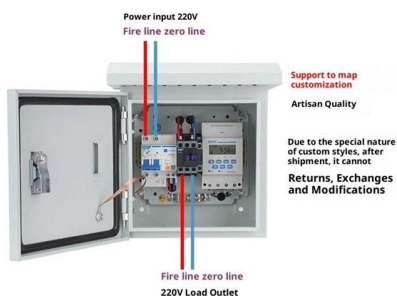

Power Distribution Boxes Explained Simply

Discover the essentials of a Power Distribution Box--how it works, key types, benefits, and tips to ensure safe, efficient electrical power management.

Electrician's Guide: Installing Distribution Boards

Explore a comprehensive guide on installing electrical distribution boards in building



12 types of distribution boxes and how to choose them

Choosing the best distribution box isn't rocket science, but it does need a bit of thought. I'll walk you through the key factors to consider, like your building size, budget, and environment.

What is an Electrical Distribution Box? A

An electrical distribution box is often called the control hub of a building's electrical system, and for good reason. It's where power from the main

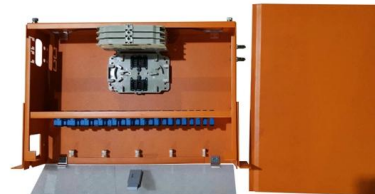

Step-by-Step Guide to Install MCB Distribution Box

Whether upgrading an aging electrical panel or setting up your facility, this guide will walk you through the critical steps to installing an MCB Distribution Box safely.



Where is the best place to put a Electrical distribution box?

Additionally, if the box is located in an area with high humidity or moisture, it is important to take steps to mitigate these effects - consider using cooling fans and dehumidifiers to ensure your



Product Catalog



Distribution Box Installation: A Complete Guide to Safe

The distribution box, often referred to as a breaker box, fuse box, or electrical panel, is a critical component of any electrical system. It acts as the central hub for

Distribution Box: Types and Functions , Axis-Electricals

A distribution box ensures that electrical supply is distributed in the building, also known as a distribution board, panel board, breaker panel, or electric panel.



The Importance of Distribution Boxes in Electrical Systems

Distribution boxes are an essential component of any electrical system, providing a safe and reliable way to distribute power to various circuits in



How to Build an Electric Distribution Box

Building an electric distribution box can be a useful and rewarding DIY project for those who are familiar with electrical wiring and safety procedures. An electric distribution box, also known as



How to Install a Distribution Box--A Comprehensive

Before starting the installation, finding a proper place for putting the distribution box is crucial, because it largely decides the safety and convenience

Distribution boards components

Distribution boards (generally only one in residential premises) usually include the meter (s) and in some cases (notably where the supply utilities impose a TT earthing system and/or tariff

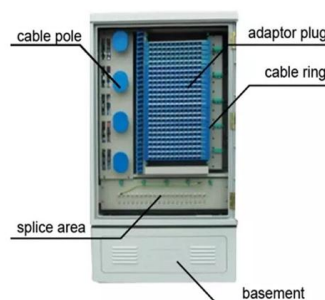



The Complete Guide to Distribution Box: Installation, Types & More

Distribution boxes form the foundation of safe and reliable electrical systems. Understanding their components, installation requirements, and maintenance needs helps you make

Distribution Boxes Explained: Types, Functions, and

Learn about distribution boxes, their types, functions, and safety features to ensure efficient and secure electrical power distribution in any building.



Distribution Boards

Distribution boards, often referred to as electrical panels or breaker boxes, serve as the nerve center of any electrical system. Here we explore the crucial parts of a distribution board and gain insights into

ITPro Today, Network Computing, IoT World Today combine

ITPro Today, Network Computing and IoT World Today have combined with TechTarget . The page you are looking for may no longer exist.



Focus creates quality products



How to Choose a House Distribution Box , CHINT global

A well-chosen distribution box ensures the safety and efficiency of your household electrical system. This article guides you through selecting a

How to Install a Cable Distribution Box Safely and

Whether it is residential buildings, commercial facilities or industrial sites, the correct and safe installation of distribution boxes is crucial to ensure

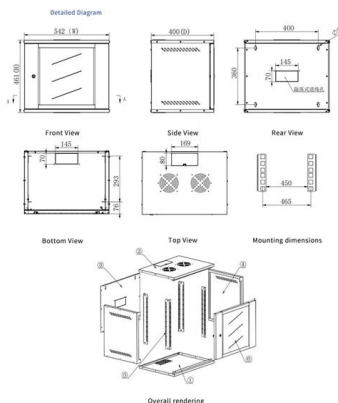

Distribution Box Guide: Types, Components & Solutions

Understand distribution boxes (DB boxes) in 5 minutes. Learn about types, components, functions, and uses. Find the perfect DB box for your needs.



Distribution box

A distribution box, also known as a fuse box or power distribution box, is the heart of the domestic electrical installation. It is used to distribute the electricity supplied by the energy supplier to the



Power Distribution Boxes Explained Simply

Learn what a power distribution box is, how it works, key components, types, and why it's vital for safe and efficient electrical systems.



DB BOX(Electrical Distribution Box): Everything You

Learn everything you need to know about the Electrical Distribution Box (DB Box). Explore types, materials, installation tips, etc.

Requirements And Specifications For Installation Of

The installation requirements and specifications of Distribution box involve many aspects, including site selection, fixing method, wiring specifications

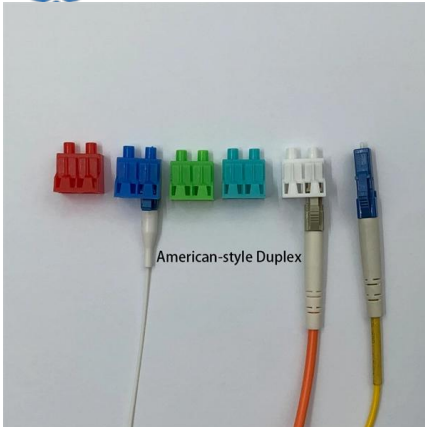

Contact Us

For datasheets, pricing, or custom telecom energy solutions, please visit:
<https://www.koskolong.co.za>