

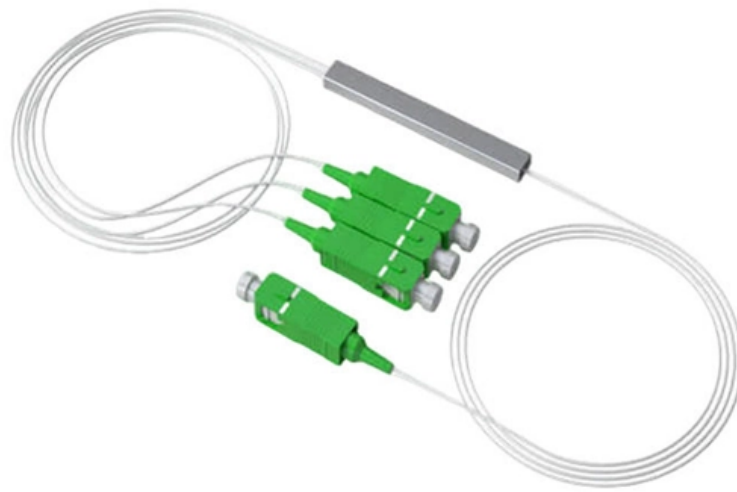

**Adam Tas Corridor Energy**

# **Fireproof cable tray fire plug price**





## Fireproof cable tray fire plug price

---

### Fire Rated Cable Tray

Cable tray designed to offer continuous support of cables Rated load of 12.5kg per metre over a 1.5m Span 1500mm Trapeze Support Spacing Complies with



### Fire Rated Cable Tray, Heavy-Duty Cable Tray Manufacturer

Boost your electrical needs with our Fire Rated Cable Trays that are tested for fire resistance under real-world conditions. Designed to perform even with cables installed and connected.



### Why Choose Fireproof Cable Trays for Safety?

Fireproof cable trays can be employed in a wide range of applications, including commercial buildings, hospitals, data centers, and even residential setups where fire safety is a

### Fire sealing cable penetrations

Cable penetrations and fire safety There are many different types of cables and cable penetrations that can pass through fire



compartment walls. For example,



## Trunking and cable trays

Our range of trunking and cable trays products are ideal fire protection solutions for electrical services passing between walls, floors and ceilings.

## Fireproof Channel Cable Tray System

The fireproof channel cable tray system is produced by galvanized channel cable tray after processing surface treatment of a layer of fireproof coating. In addition,



## Fire Rated Cable Tray, Heavy-Duty Cable Tray Manufacturer

Fire Rated Cable Trays that are crafted from premium materials like stainless steel, galvanized steel, tempered glass, and fire-resistant polyester fiberglass. Each tray is coated with a specialized fire



## Fire resistant cable tray , Hermi-solutions

Cable trays are intended for the construction of fire-resistant cable paths with surface cable laying. Cable paths are constructed as standard or lightweight cable paths.



## What are the fireproof characteristics of cable trays?

Only the fire-proof and flame-retardant principle of cables and fire-resistant coatings are on fire. At present, fire-resistant cable racks are mainly

## Fire-Resistant Cable Support Systems

Meka Pro's more than 1200 fire-tested standard products enable always excellent, cost-effective and fire-resistant installation. Guarantee, that electricity supply will



## Industrial Grade Fireproof Cable Tray for Secure Cable

Good fireproof performance: fireproof cable tray is made of fireproof



### **CFS-BL Firestop Block**

More information Customers also searched for firestop brick, block, cable tray, pillow or brick.



### **FIRE RESISTANT PROOF CABLE TRAY, DIN STANDARD E90**

Cablofil cable tray is the preferred choice for the cable containment of low and high voltage electric cables where fire resistance is crucial - this includes cable basket tray systems for Prysmian FP



### **Trunking and cable tray protection**

Our range of trunking and cable tray protection products provide effective fire protection for pipes, cables and trunking within floors, walls and ceilings.



### **Cable tray fire protection solutions**

Cable tray fire protection Cable tray fire protection Cable tray fire protection: Go onto any rig, into any petrochemical plant, factory, production plant, hospital, office or



### Fire stop section of the cable tray and cable management NEMA

The resulting barrier retards the transmission of smoke, fire, and toxic gases from spreading between adjacent rooms and floors for the rated time period. The following charts give the number of 3M



### Electrical Cable Tray Fire Protection

One of the most significant fire protection requirements for processing facilities and offshore locations is the need to protect control cables and control

### Fire protection for cables & cable trays , Flamro

Fire protection for cables and cable trays: effective solutions to prevent cable fires Cable systems are found in all buildings nowadays: from industrial plants via

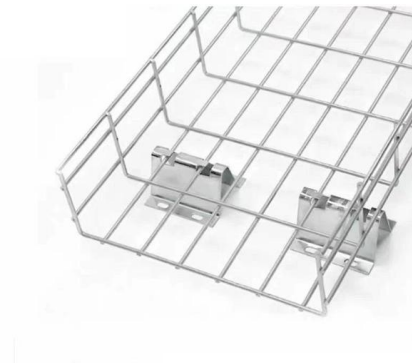



## Fire Resistant Cable Tray for Sale - 2026

Find top-rated fire resistant cable trays for sale with customizable options. Compare prices, MOQs, and supplier ratings. Click to explore verified suppliers and get the best deals in 2026.



## Buy Fire Rated Cable Fixings , Fast UK Delivery , CMW

Our wide range of fire rated cable fixings are perfect for electricians and IT professionals. With various conduit clips, F clips, Safe-D clips and Safe-D spring clips, we have the perfect product to suit your

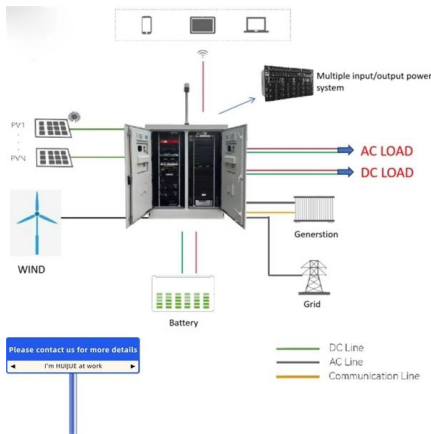
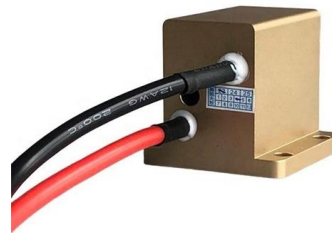

## Fire-resistant cable tray

Find out all of the information about the NIEDAX product: fire-resistant cable tray . Contact a supplier or the parent company directly to get a quote or to find out a

## FIRE RESISTANT PROOF CABLE TRAY, DIN STANDARD E90

Cablofil Cable Basket - Fire Resistant Cable Tray for FP (Fire Proof) Cables Cablofil cable tray is the preferred choice for the cable containment of low and high voltage electric cables where fire



### **On Sale Fireproof Cable Tray Powder Coated Surface , Alibaba**

Shop high-quality fireproof cable trays from reliable suppliers. Durable, perforated, and powder-coated for indoor and outdoor use. Bulk orders welcome.



### **Cable Trays, Fire safety solutions**

The stock and the price of the product are for information only and may change during the day.



## **Contact Us**

---

For datasheets, pricing, or custom telecom energy solutions, please visit:  
<https://www.koskolong.co.za>