



**Adam Tas Corridor Energy**

# **Ftth Network Fiber Distribution Box**





## Ftth Network Fiber Distribution Box

---



### 16 Core Outdoor FTTH Fiber Distribution Box IP65 Waterproof Fiber

This 16-core fiber distribution box is a professional outdoor enclosure designed for FTTH/FTTX access networks. Made of high-strength ABS+PC material with IP65 waterproof rating, it integrates fiber

### High-Quality FTTH Fiber Boxes

Suitable for indoor and outdoor environments, these enclosures support wall-mounted or pole-mounted installation, ensuring reliable fiber termination and



### How to Choose the Right Fiber Distribution Box for

Selecting the right fiber distribution box (FDB) is a critical decision for any FTTH, FTTB, or campus PON deployment. As the junction point for fiber

### Fiber Optic Distribution Box

TUOLIMA, a professional FTTH distribution box supplier, has been manufacturing fiber optic distribution box for over 10 years exporting to



five continents. We have



### **FTTH distribution boxes 4, 8, 16, 24, 36 or 48 ports**

Premium-Line FTTH distribution box is aim designed for multi-purpose applications in FTTH projects, the dual layer design supports direct termination, and also FTTH

### **Fiber Optic Distribution Box -- FTTH & ODN , TTI Fiber**

In FTTH and FTTB networks, the distribution box is the critical junction between the backbone distribution cable and the last-mile drop cables that reach each home or office unit.



### **What is fiber to the home (FTTH)?**

In FTTH access networks, fiber optic cables run from a central office through a fiber distribution hub. The cables then run through a network access point and finally into the home



## Best Outdoor Water-proof FTTH Distribution Fiber Optic Termination Box

Wall Mount Fiber Termination Box: Empowering FTTH Fiber Installation with Ease Serving as a critical connection point, outdoor termination box facilitates the termination, splicing, or connection of fibers



## FTTx Access Network Boxes Explained in FTTH Systems

Engineering explanation of FTTx access network boxes including distribution roles, structural functions, and deployment boundaries in fiber access networks.

## Fiber to the x

FTTH (fiber-to-the-home): Fiber reaches the boundary of the living space, such as a box on the outside wall of a home. Passive optical networks and point-to-point



## Fiber Optic Cable, Clamps, Boxes, for FTTH

JERA LINE-China Factory produce high-quality fiber optic cables, fiber cable clamps, and fiber optic boxes for outdoor & Indoor FTTH. ISO 9001 certified.



## ETS Fiber Optic Distribution Box 2 Core

The Fiber Optic Distribution Box is a premium solution designed to efficiently manage, protect, and distribute fiber optic cables in both indoor and outdoor environments. Available in 2, 4, and 8-core

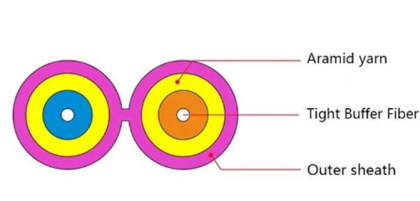

## 12 Port FTTH Fiber Distribution Box for 1x8 Blockless

The 12 port ftth fiber distribution box is designed for connecting feeder cables and drop cables in fiber access networks. It is widely used in MDUs (multi-dwelling

## Fiber Termination Box Manufacturer , FTTH FTTx Solutions

A fiber termination box is used to terminate, splice, and distribute optical fibers in FTTH and FTTx networks. It supports multiple ports and core capacities, offering secure cable management for





## Fiber optic distribution boxes

Discover tML® tde Modular Link from tde, the modular solution for high-density fiber optic installations. Plug-and-play, scalable, and quick to install, it's ideal for data

## 24 Core FTTH IP65 Reinforced ABS Fiber Optic Distribution Box

24 Core FTTH IP65 Reinforced ABS Fiber Optic Distribution Box Kena iTuvatuva: Fully enclosed structure Durable material Integrated fiber management User-friendly design Na digidigi ni digidigi



## 12 Core Fiber Optic Distribution Boxes for FTTH

12 Core Fiber Optic Distribution Boxes for Indoor/Outdoor Connectivity with IP 65 Protection.

## Fiber To The Home Network Design

There is really no way to generalize on the design process for fiber to the home (FTTH) networks - or any fiber optic network for that matter - since every system



### Fiber Distribution Box 1x24 , Outdoor FTTH Splitter Box

The Fiber Distribution Box 1x24 is a robust, weatherproof enclosure designed for distributing and terminating up to 24 fibers in FTTH/FTTX networks. It supports



### FTTH Fiber Distribution Box Supplier

Teleweaver FTTH distribution box is aim designed for multi-purpose applications in FTTH networks, The dual layer design FTTH distribution box supports direct

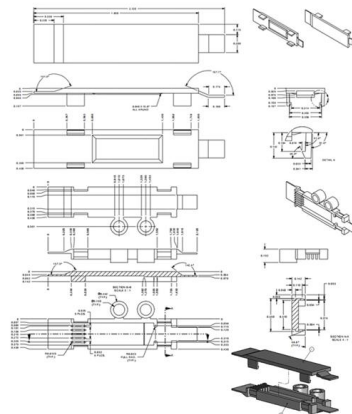

### 1x8 PLC Fiber Splitter 12 Core SC SM FTTH Fiber Optic Terminal

The splitter termination box is suitable for fiber terminal point to complete connection, distribution and scheduling between perimeter fiber cables and terminal equipment, especially suitable for mini





## High quality FTTH junction box, 48 core IP55 fiber optic

The FDB-48 Series 48-port Fiber Distribution Box is suitable for FTTH projects and can be used in corridors, basements, rooms, and on building exteriors. It has



## Durable FTTH Terminal Box , Fiber Termination

Explore reliable FTTH terminal boxes for secure fiber termination and distribution. Wall-mounted design, robust build, for home and industrial optical networks.

## Fiber Optic Breakout Box 1 Inlet 6 Outlet FTTH Mini 4 / 6 Fiber Optic

Fiber Optic Breakout Box 1 Inlet 6 Outlet FTTH Mini 4 / 6 Fiber Termination FDB Box Description: It is especially for connecting and protection for fiber cable for FTTH. This fiber optic terminal box applies

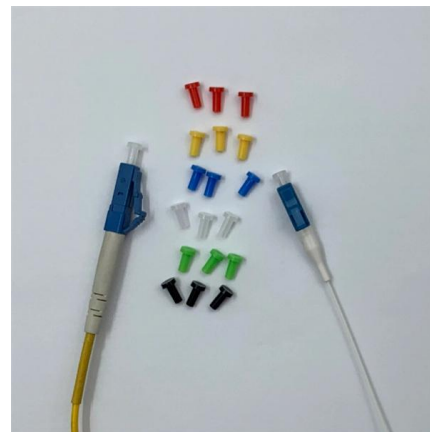

## Ftth box 24 ports cores ODP box fibra optica FTTH caja

Suited for FTTH engineering cables reaching buildings, it can be installed in corridors, basements, computer rooms and exterior walls. It enables fiber



## Fiber Optic Wall Plate Guide for FTTH & Telecom Networks

FTTH Signal Flow: Central Office (OLT) -> Distribution Fiber Cable -> Fiber Distribution Box (FDB) -> Network Interface Device (NID) -> Fiber Optic Wall Plate -> Fiber Patch Cord -> ONT / Router ->



## Fiber Box Solutions for FTTH: Key Functions, Applications, and

A clear guide to fiber box solutions in FTTH and ODN networks. Learn how fiber boxes support splitting, routing, and efficient deployment for telecom projects.



## 24 Ports Wall Mounted Fiber Splitter Distribution Box

Description This outdoor 24 ports fiber distribution box provides a protected termination point for feeder cable to connect with drop cable in FTTH and FTTx





## Amazon : Fiber Distribution Box



ETS Fiber Optic Distribution Box 4 Core - IP65 Waterproof, UV Resistant, FTTH, FTTx, Wall/Pole Mountable, Industrial Networks, Fusion Splicing, SC/LC/FC Adapters, Cable Management Add to cart

## FTTH Products , OLT, ONU, Optical Splitters, Fiber

Discover essential FTTH products like OLT, ONU, optical splitters, and fiber distribution boxes. Learn how to design and deploy an efficient FTTH network for



## Contact Us

---

For datasheets, pricing, or custom telecom energy solutions, please visit:  
<https://www.koskolong.co.za>