



Adam Tas Corridor Energy

How to allocate power distribution boxes





How to allocate power distribution boxes

What Is an Electrical Distribution Box? A Complete Guide

What Is an Electrical Distribution Box? An electrical distribution box serves as a centralized unit for distributing electrical power within



How to Choose the Right Distribution Box?

How to choose the right distribution box for a specific application is crucial for ensuring safe, efficient, and reliable power distribution. Different



Distribution Box and Selection Guide

This guide provides information on how to select the appropriate Distribution Box for Electric project. If you have any questions about distribution



Cable Distribution Box Layout: 10 Industrial Strategies

Optimize your cable distribution box layout for safety and efficiency. Learn industrial best



practices using Chuanli's IEC-standard outdoor and custom boxes.



What does a power distribution box do ?

The main function of the distribution box is to receive power and distribute it to various circuits. It can protect circuits, regulate voltage, and isolate and control

Comprehensive Understanding of Distribution Box

Modern distribution boxes, also called breaker panels or fuse boxes, handle different voltages and loads. They have safety tools like circuit breakers and fuses that stop power during problems.



What is a DB Box? Types, Wiring, Selection Guide

Learn everything about DB box (distribution box): what they are, how they work, wiring diagrams, types, and how to choose the right one.



Understanding Distribution Boxes:A Comprehensive Guide

Understanding its significance, this article covers what a distribution box is, how it functions, its structure, the various types available, and how it



Understanding Distribution Boxes:A Comprehensive Guide

A distribution boxes is an essential device that manages the safe and efficient flow of electrical power throughout different areas of a building or facility.



Ultimate Guide To Distribution Boxes Db Boxes Types

This ultimate guide explains what a distribution box does, its internal components, common types, real-world applications, and how to select the right DB Box for



Understanding Distribution Boxes: A Comprehensive Guide

Learn what a distribution box is, its types, and how to choose the right one for your project. Includes clear examples and expert tips.

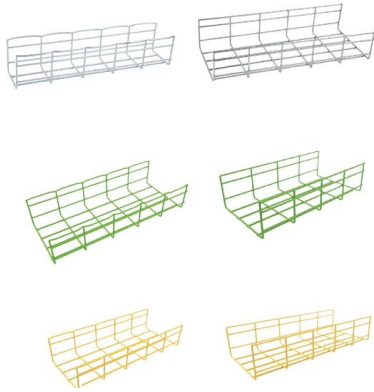

Distribution Boxes: Types and Functions

A distribution boxes acts as the load center and main distributor of electrical power within a building. Also called a distribution board, panel board,

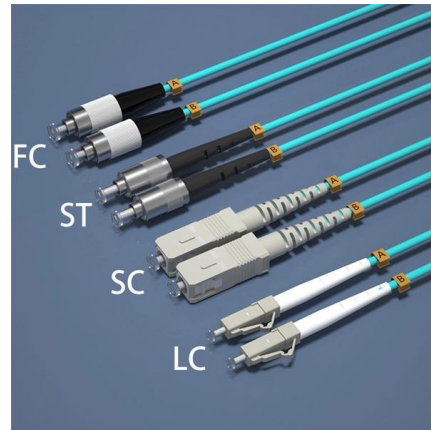

What Is a Distribution Box?

Some distribution boxes have a longer cord than others. When choosing a distribution box, make sure the cord is long enough to reach the main

How to Install a Distribution Box--A Comprehensive

An electrical distribution box, also known as a power distribution box, panelboard, or consumer unit, is the core of an electrical system. It has three

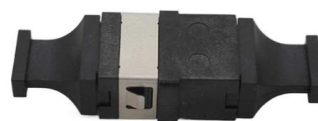



The Importance of Distribution Boxes in Electrical Systems

A distribution box is an exposed or concealed metal box that houses the circuit breakers that regulate the distribution of electricity throughout a

Understanding Power Distribution Boxes: Types, Features, and

This guide delves into the intricacies of power distribution boxes, shedding light on their design, functionality, and regulatory standards. Readers can expect to gain a comprehensive



Everything You Need to Know About Temporary Power

What are some common applications for temporary power distribution boxes? We'll explain how they work and benefit your business. [Learn more here!](#)

Distribution Box Guide: Types, Components & Solutions

Understand distribution boxes (DB boxes) in 5 minutes. Learn about types, components, functions, and uses. Find the perfect DB box for your needs.



Understanding Distribution Boxes: A Comprehensive Guide

A distribution box is a vital piece of equipment that ensures the effective and safe distribution of electrical power in various parts within a building

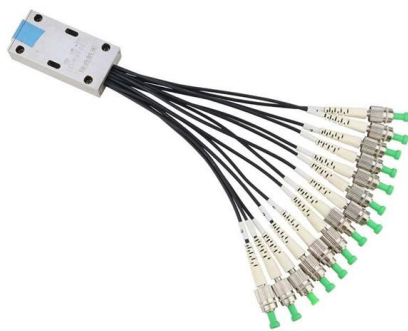

Understanding Distribution Boxes: Your Guide to Power

What are the different types of distribution boxes? The table below provides a comprehensive overview of various distribution box types and

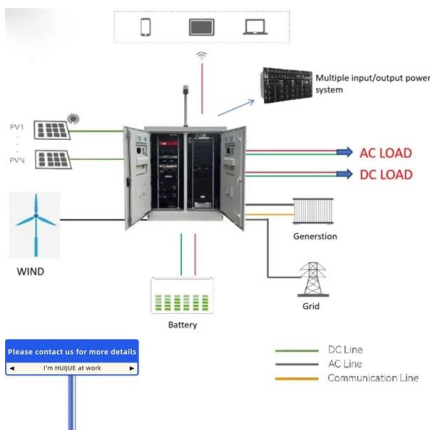

Electrical Boxes , NWPX Park

These boxes organize and manage cables, prevent tangling, and ensure that cables are routed properly. Organized cables simplify maintenance and minimize the risk



Electrical Power Distribution Boxes for Temporary Event

Conclusion Power distribution boxes are an integral part of any temporary event setup, ensuring that power is delivered safely and efficiently to



Explore Power Distribution Box Types and Functions

Power distribution boxes are used in commercial and residential buildings and are part of the electrical system, also known as switchboards.

What is a DB Box? Types, Wiring, Selection Guide

Learn everything about DB box (distribution box): what they are, how they work, wiring diagrams, types, and how to choose the right one.



How to Use a Power Distribution Box?

Learn how to safely use a power distribution box with our step-by-step guide. Ensure reliable performance and prevent electrical hazards.



How Does a Power Distribution Box Work

Learn how a power distribution box works step by step--from incoming power to circuit protection and smart monitoring--for safe, efficient electricity delivery.



The Ultimate Guide to Distribution Box Types

Discover the key types of distribution boxes with NUOMAK's comprehensive guide. Learn about Main Distribution Boards (MDB), Consumer Units, Transfer

What is the Function of a Distribution Box in Electrical Systems

How the Distribution Box Allocates Electricity to Circuits The distribution box is the main control center for electricity. It links the power from the utility company to your home circuits. Inside, tools like circuit





Industrial Plant Distribution Box Layout and Power Distribution

The distribution box isn't just metal and wires - it's the control center deciding which equipment gets power, how much, and when. Get its layout wrong, and you're building headaches into your

A Definitive Guide To Distribution Boxes

The distribution box acts as the center of power distribution, distributing electricity to all connected devices. A distribution box, also known as a distribution board, panel board, breaker



Power Distribution Box

It is possible to expand with more DC distribution boxes in the same system. We recommend connecting multiple DC distribution boxes together by putting 2 parallel cables on the incoming DC in the



How to Install a Cable Distribution Box Safely and

In modern electrical systems, cable distribution boxes (also known as electrical distribution boxes or distribution boxes) play a crucial role as the key



Power Distribution Boxes Explained Simply

Learn what a power distribution box is, how it works, key components, types, and why it's vital for safe and efficient electrical systems.

Contact Us

For datasheets, pricing, or custom telecom energy solutions, please visit:
<https://www.koskolong.co.za>