

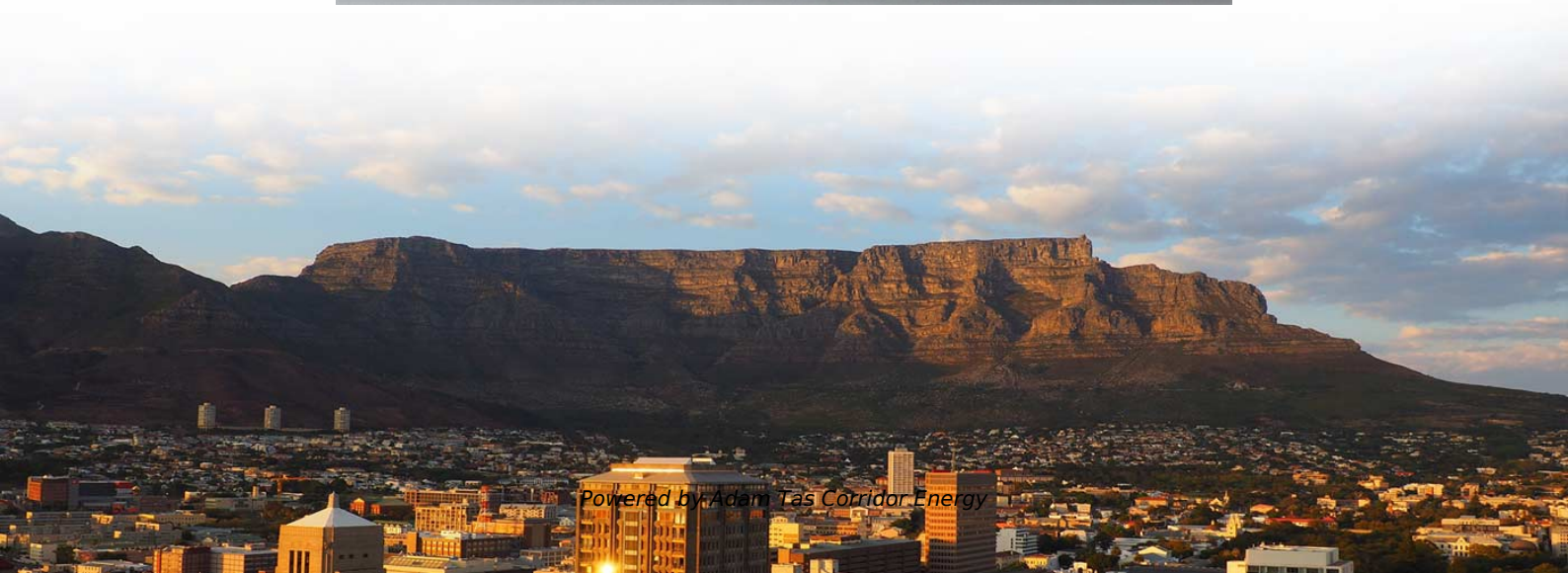

**Adam Tas Corridor Energy**

# **Industrial Explosion-Proof Quick-Connect Distribution Box**

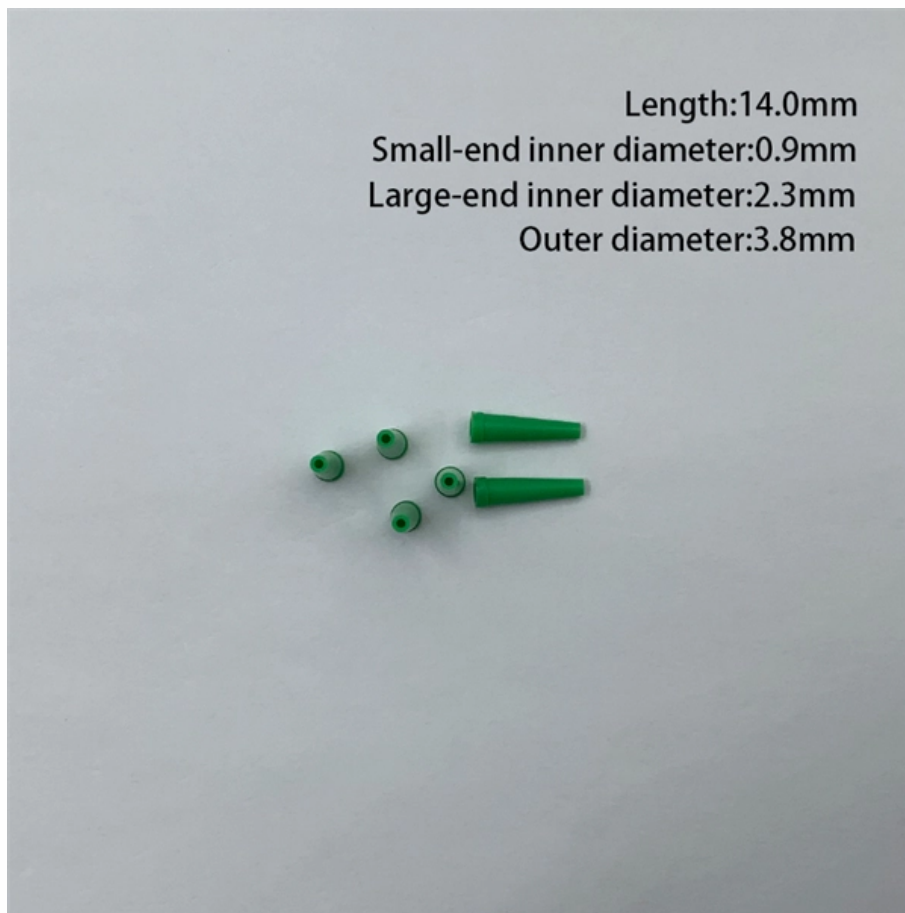



## Industrial Explosion-Proof Quick-Connect Distribution Box

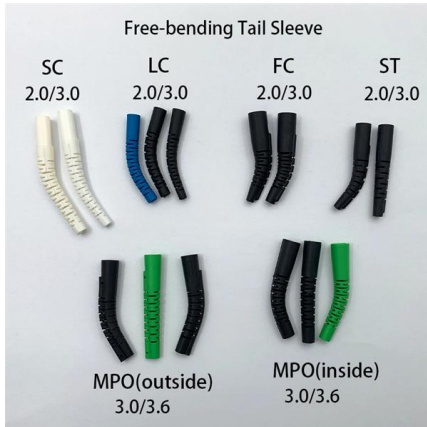

### Expert Guide: Select the Right Temporary Power Distribution Box

The right distribution box that matches your power requirements, durability needs, and weather resistance will give optimal performance for specific applications. Note that successful power

### Explosion-Proof Distribution Boxes & Panels Manufacturer

The explosion-proof distribution box safely delivers power in hazardous zones (oil, gas, chemical plants) with rugged, spark-resistant casing--ATEX/IECEX, IP66 certified for reliable operation in explosive



### Terminal boxes , Junction boxes , Ex , Ex e , Ex d , ATEX , Explosion

Safely conduct, connect and distribute energy in hazardous areas with R. STAHL's terminal boxes. We offer bespoke, custom-made terminal boxes and terminal box combinations, as well as standard



### Flameproof Distribution Board , Explosion proof

An ordinary distribution board may generate heat and sparks due to heavy usage. Thus, the



flameproof/explosion-proof distribution box/panel is used in hazardous



### **BM (D)X-Series Explosion Protected Distribution Box**

BM (D)X-Series Explosion Protected Distribution Box Explosion protection -IECEX (IEC) -ATEX (CENELEC,EN) -China Ex (GB) Application in hazardous area



### **Explosion Proof Plug and Socket, Junction Box Price,**

We provide Explosion proof various equipment's like plug and socket, junction box, cable glands and control panel assembly in UAE as per ATEX standard &



### **DISTRIBUTION BOARDS**

Extol International are the leading suppliers of Control Panels & Distribution Boards for hazardous areas and explosive atmospheres - a comprehensive range of Explosion Proof control panels are available





## Explosion-Proof Junction Box for Hazardous Areas

Explore the features, working principles, and benefits of an Explosion-Proof Junction Box -- essential for safe electrical connections in hazardous



## "Explosion Proof Distribution Box"

The Explosion Proof Distribution Box is a key item within our extensive Power Distribution Cabinet & Box selection livery speed for power distribution cabinet & box depends on order size, OEM specs,

## Explosion Proof Junction Box Types, Prices

Explosion-Proof Junction Boxes: Pricing, Sizes & Installation Guide In hazardous locations where flammable gases, vapors, or dust are present,



## Ex Local Control Stations & Distribution Boxes

Atex control stations, explosion protected control units and distribution boxes made stainless steel maritime grade AISI 316L or AISI 304L. Atex Delvalle provides a



### Explosion-Proof Distribution Box , Safe Power Control - DDY GROUP

Why Choose an Explosion-Proof Distribution Box  
This explosion-proof distribution box is built for reliable protection in demanding industrial settings. It supports stable distribution and helps reduce risks



### 12/24 ways black explosion-proof socket distribution box

Tax excluded, add at checkout if applicable  
12/24 ways black explosion-proof socket  
distribution box industrial portable outdoor  
socket box rainproof overhaul box

### Explosion-Proof Distribution Box , Product Center

Explosion-proof distribution boxes are designed to safely control and distribute electrical power in hazardous environments, preventing ignition risks.

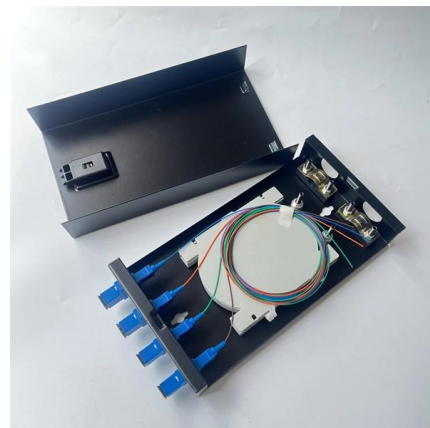

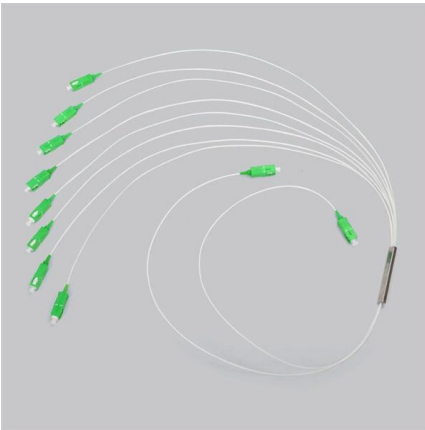

### **Atex Certified Junction Boxes, Terminals, Sockets**

These explosion proof junction boxes / terminal boxes, plugs, sockets & connectors are for use in explosive atmospheres in compliance with the ATEX 94/9/EC

### **Ex Distribution Boards & Enclosures , mlx-ex**

Ex distribution boards - Explosion-proof distribution boards designed for Ex and ATEX areas. Customizable, safe, and certified electrical solutions.

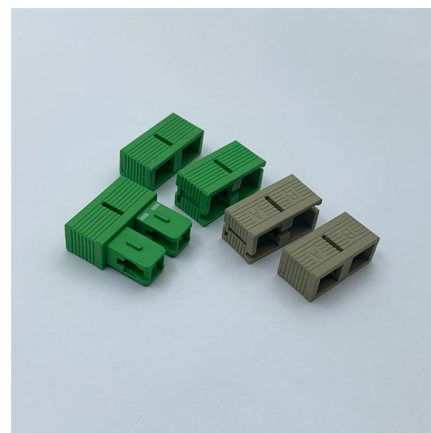

### **6WAY EXPLOSION PROOF DISTRIBUTION BOXES,**

BESIDES THE PRESENT DESIGNATION FOR THE FULL PLASTIC EXPLOSION-PROOF MOBILE POWER BRANCH CONNECTION SOCKET BOX, IT ALSO

### **Power Distribution Systems , Explosion Protected , R. STAHL**

Evolution in Power Distribution For decades, the only explosion protection technology available in North America was the cast metal enclosure systems designed for Class I, Division 1 environments, also



Length:14.5mm  
Small-end inner diameter:2.0mm  
Large-end inner diameter:3.5mm  
Outer diameter:5.2mm



## Ex-Proof & Flameproof Enclosures & Junction Box , Supermec

All explosion-proof enclosures, lighting or power distribution boxes are manufactured using the latest technologies, both mechanical and electrical, using materials able to resist in most highly corrosive

## Explosion Proof Distribution Box & Electrical Enclosures

Durable Hexlon Explosion Proof Distribution Boxes and Electrical Enclosures, IECEx and ATEX certified for Zone 1 and Zone 2.



## Explosion proof Power Distribution Panel Box

Power Distribution panel box - Hazardous locations for explosive gas mixtures: Zone 1 and Zone 2. Explosive gas mixtures: Class IIA, IIB, and IIC.



## Explosion Proof Distribution Box , ATEX Transformer Supplier

We supply certified explosion proof distribution box & ATEX Transformer -Appleton, ATKON, CZ, CEAG, brands for safe and reliable industrial use.



## Explosion-proof distribution box: the "invisible guard" protecting

In high-risk industries such as petrochemicals, mining, and pharmaceuticals, the stability and safety of power equipment are crucial. The explosion-proof distribution box is the "invisible

## Explosion-Proof Distribution Box , Safe Power Control - DDY GROUP

This explosion-proof distribution box is built for reliable protection in demanding industrial settings. It supports stable distribution and helps reduce risks linked to exposed electrical components.

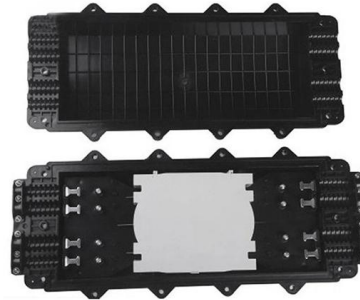

## Terminal Box/Explosion proof electrical equipment/global certification

KHJ offers a large selection of terminal boxes and junction boxes for wiring connection in explosion hazardous areas. They are certified according to the latest ATEX and IEC EX standards.



## How to Wire an Explosion-Proof Distribution Box and

Explosion-proof electrical equipment, such as explosion-proof distribution boxes, is specifically designed for hazardous environments where flammable gases,

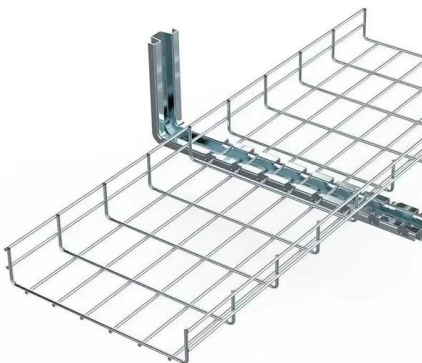

## IP66 Explosion Proof Distribution Boxes for Hazardous Areas

Shop high-quality IP66 explosion proof distribution boxes for safe and reliable electrical installations in hazardous areas. Find durable, customizable solutions now.

## Explosion Proof Enclosures , Complete Hazardous Area

Learn everything about explosion proof enclosures for hazardous areas--design, certification, and industrial applications with ATEX, IECEx, and Class I Div





## Contact Us

---

For datasheets, pricing, or custom telecom energy solutions, please visit:  
<https://www.koskolong.co.za>