

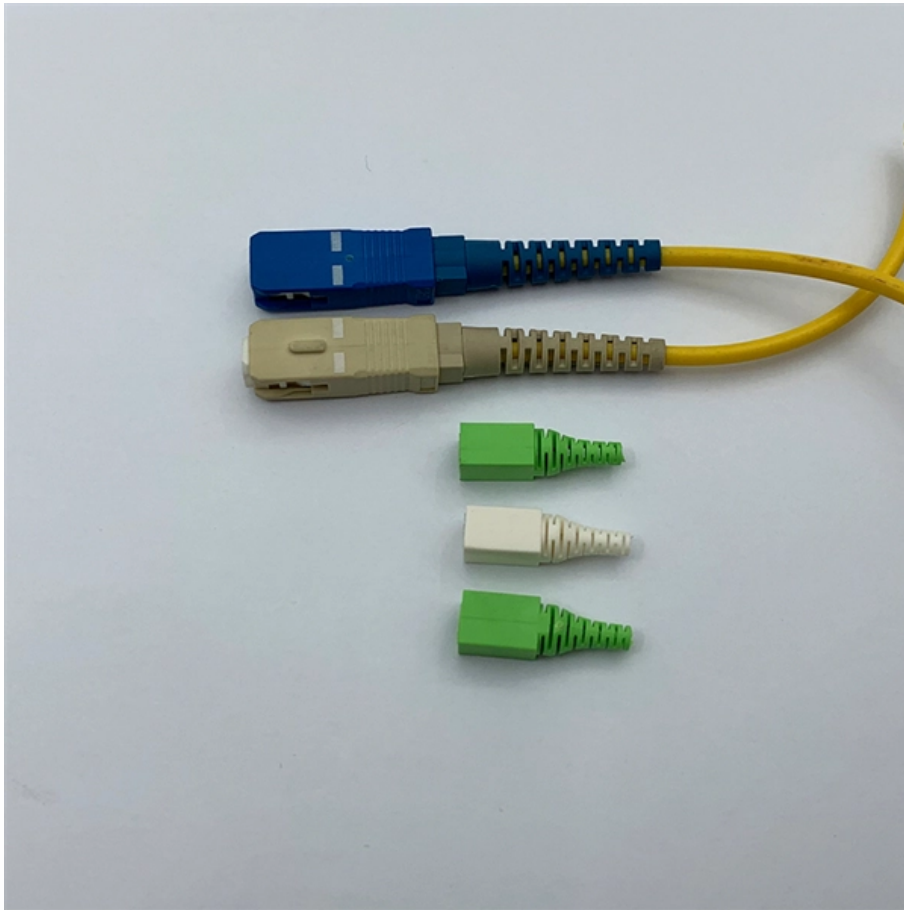

**Adam Tas Corridor Energy**

# **Inner Door Protection Distribution Box**





## Inner Door Protection Distribution Box

---



### MEI IP 65 Inner out double door metal enclosure control

we have IP66 and CE approval for MEI IP 65 Inner out double door metal enclosure control box

### Waterproof Electrical Distribution Box, SHPN Series

The Waterproof Electrical Distribution Box, with its high-definition transparent cover, is a transparent panel that not only allows for easy monitoring of the internal



### Inner Doors For Power Distribution, DI , nVent HOFFMAN

Inner Doors For Power Distribution, DI Displays and indicators can be mounted on a surface within the enclosure while covering other components, and preventing

### Key Material Requirements for Distribution Box

Learn the key material requirements for distribution box, Discover how the right materials



ensure long-lasting performance and safety.



## DISTRIBUTION BOX

VIOX offers high-quality stainless steel distribution boxes in 201, 304, and 316 grades. From cost-effective indoor solutions to corrosion-resistant options for



## Distribution Protection Box, IP65 Transparent Cover

Distribution Protection Box, IP65 Transparent Cover Electrical Box, ABS Power Supply Electronic Junction Box for Circuit Breaker Indoor on The Wall 3 Way,



## FM guide to the selection of enclosures for distribution boards

All equipment must be installed following state-of-the-art procedures and in compliance with the manufacturer's assembly instructions. If components with varying classes of protections are installed,





## Complete Guide For Distribution Boxes Types

Distribution boxes, also known as electrical distribution boards or panels, are pivotal components in electrical systems, ensuring the safe and organized distribution of

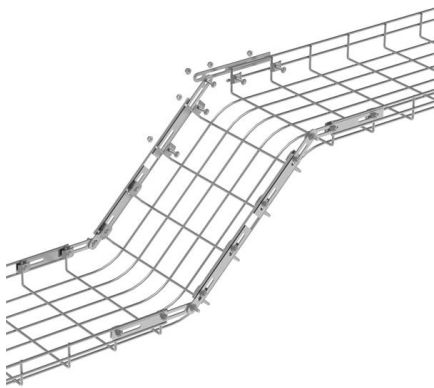

## Waterproof Distribution Boxes for Electrical , WZMDBOX

Manufacturer & Exporter of Junction Boxes, Electrical Boxes, Plastic Enclosures, Waterproof Distribution Boxes and other waterproof box products. The product is

## Sieno IP66 Class Waterproof Metal Distribution Boxes

Sieno-IP66-Waterproof-Metal-Distribution-Boxes Designed to enclose electrical and or electronic equipment and protect against harsh, industrial environments. For use as instrument enclosures,



## The Importance of Distribution Boxes in Electrical Systems

Learn more about how distribution boxes play a critical role in the safe and efficient operation of electrical systems.



## Metal Enclosures, IP 65

Features/Benefits Used as low voltage distribution boxes. Metal keys and locking mechanism for durability. Earthing studs are provided on both the enclosure and the door. Easily removable hinges,



## Distribution Box with Inner Door

Distribution Box with Inner Door, Find Details and Price about Distribution Box Wall Mount Enclosure from Distribution Box with Inner Door - Wenzhou Xujie Electric

## Ex d Enclosure Series

The Ex d IJB series of enclosures is suitable for use in Gas Group IIB+H2 for the protection of electrical and control-system solutions, such as energy distribution, monitoring of processes and the complex

### LoRawan outdoor base station

- \* Industrial Internet gateway
- \* Compatible with LoRaWAN network,
- \* ClassA/B/C mode
- \* Support 8/16 channel
- \* Supports PoE power
- \* supply and backup battery power supply
- \* 10KV lightning protection



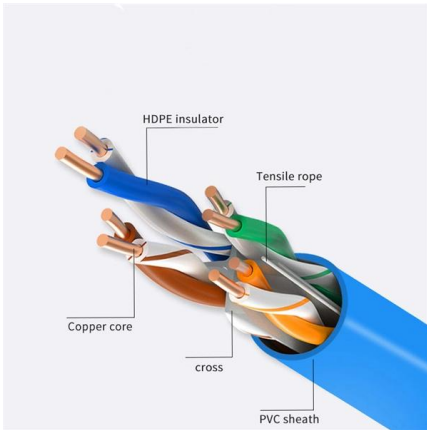

## Circuit Breaker Distribution Box Electrical, Outdoor

MAKERELE IP65 waterproof distribution protection box, made of ABS plastic, and the use of plastic transparent cover is convenient to check the running status of

## Enclosures and Distribution boxes , Sonderhoff

Henkel's polyurethane or silicone sealing foams protect the electronics in control cabinets and electrical distribution boxes against external influences, such as

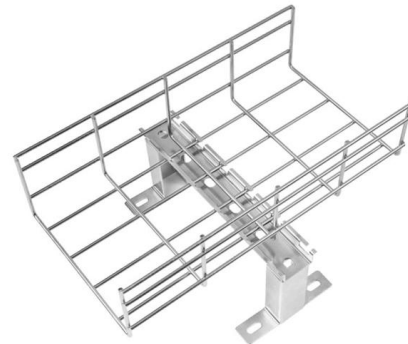

## Distribution Box Guide: Types, Components & Solutions

It acts as a protective enclosure that houses several key components, such as circuit breakers, fuses, and bus bars. These components work together

## MOLLUM DIN Rail Circuit Breaker Distribution Protection Box

Greatly improve the safety of the circuit breaker. Impact resistance up to IK08. This power distribution protection box can be easily installed and very convenient to use, just need a few steps to mount it



### **2-Way Distribution Protection Box, IP66 Waterproof**

About this item Transparent Cover: This 2-way electric panel DIN distribution box provides safety protection for your wall circuit, the surface is a transparent gray



### **HA Series IP65 Waterproof Power Distribution Box**

Crafted with advanced materials and innovative structures, it delivers reliable and stable performance in harsh environments, including humid, dusty, or outdoor



### **ABS plastic electrical distribution box with IP65**

Wall mounted electrical distribution box. Metal cabinet type design with door. IP65 environmental protection, which allows the distribution box to be installed





## Fuse Box Surface-Mounted Distributor IP65 5 Distributor Protection Box

Fuse Box Surface-Mounted Distributor IP65 5 Distributor Protection Box with Clamps and Top-Hat Rail, with Door, Suitable for Indoor and Outdoor Use, Meets the Wet Room Standard Brand: Fiabgum 4.8



## Industrial Distribution Box , IP67 Power Enclosure

Advanced Protection in an Industrial Distribution Box Durability remains a hallmark of the EPCOM Industrial Distribution Box series. Every unit undergoes rigorous

## KERWINN 2 Way Distribution Protection Box,ABS/PC Alloy Plastic

About this item Product Name:Distribution Protection Box (HT-2-WAY), Size:120MM\*90MM\*54MM High quality material: PC/ABS alloy plastic, durable, sealed firmly, not easy to deform. ip66 waterproof and



## How to choose the right passive electronic lock for your

Distribution box safety is no small matter, a suitable passive electronic lock is not only the protection of equipment, but also responsible for the



## Understanding IP Protection Ratings for Distribution Boxes: Choosing

When you're setting up electrical systems, distribution boxes are like the unsung heroes that keep everything running smoothly. You probably don't give them much thought until something



## How to Choose a House Distribution Box , CHINT global

A well-chosen distribution box ensures the safety and efficiency of your household electrical system. This article guides you through selecting a

## Waterproof Distribution Box (IP65-IP68)

IP65 waterproof distribution box for outdoor installs. Plastic ABS/PC, DIN-rail ready, clean wiring, customization available. Manufacturer support & accessories.

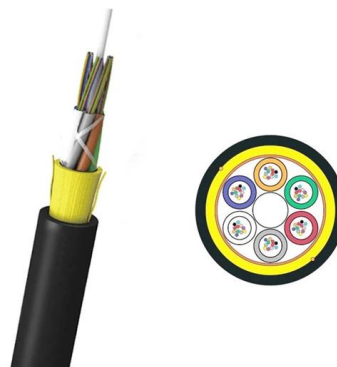



## Contact Us

---

For datasheets, pricing, or custom telecom energy solutions, please visit:  
<https://www.koskolong.co.za>