



Adam Tas Corridor Energy

Inspection fee for distribution boxes





Inspection fee for distribution boxes



Regular maintenance checklist: ensuring safe and reliable operation of

Hey there! If you're responsible for maintaining electrical systems, you know that distribution boxes are the unsung heroes of power management. These metal workhorses silently

On-site distribution box inspection - quote - 24/7 Emergency

An on-site distribution board inspection is a thorough check of your meter box, performed by certified electricians at your home or business. During this inspection, we examine the condition of the



Comprehensive Guide on Septic System Distribution

Explore a comprehensive guide on septic system distribution boxes, covering design, installation, maintenance, and troubleshooting.



The Importance Of Regularly Inspecting Stainless Steel

These changes are not easily visible externally but affect long-term stable operation. Staff need



to conduct a comprehensive inspection of stainless steel project box



Distribution Box Replacement Cost Guide 2026

Hidden fees may include upgrade to meet modern code requirements, trenching for underground feeds, or replacing the main service conductors from the utility. If a new meter socket is

Design requirements and standards for low voltage

Regularly inspect and maintain your distribution box to catch issues early and ensure safe operation. Design requirements for low voltage distribution



Key Factors Affecting Third-Party Inspection Costs , Testcoo

Discover the key factors influencing third-party inspection costs, from industry standards to geographic location. Learn how Testcoo optimizes inspection fees without compromising quality.



Electrical DB Inspection Checklist , PDF

Electrical Distribution Box (DB) Inspection Checklist - Free download as Word Doc (.doc / .docx), PDF File (.pdf), Text File (.txt) or read online for free. The



Distribution box inspection , Fast and professional electricians

This way, you know exactly what to expect and avoid any surprises. Want to know how others experience our group box inspection? Feel free to take a look at our Google reviews about

DB Box Inspection Checklist , PDF

DB Box Inspection Checklist CCYR - Free download as PDF File (.pdf), Text File (.txt) or read online for free. The document provides a 16 item checklist for



Distribution box inspection , Fast and professional electricians

What are the costs of a distribution box inspection? The cost of a distribution board inspection varies depending on the number of circuits, the complexity of the installation, and any additional



Distribution Box Replacement Cost Guide - One and Done Prep

Cost ranges include materials and labor but exclude permit fees in some areas. Typical projects fall into two categories: (1) standard replacement with the same amperage and layout, and

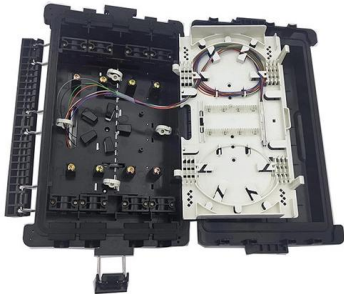

Comprehensive Guide to Septic Distribution Box Replacement Costs

In many regions, replacing a septic distribution box requires permits and inspections, which can add to the overall cost. Permit fees can range from \$50 to \$300, depending on local

DB Box Inspection Checklist , PDF

The document provides a 16 item checklist for inspecting a main distribution board or panel board.



Septic Distribution Box Replacement Cost? [2026 Data]

Septic distribution box replacement costs aren't low, but it's an item that causes obvious problems when not functioning correctly. Learn what factors



Cost To Replace A Septic Tank Distribution Box -

The septic tank distribution box, or septic d-box, is a crucial component to your septic system. The average cost to replace the septic d-box is



Factory Audits for Distribution Box Suppliers: Key Inspection Points

Today, we'll break down exactly what separates the best from the rest. Forget cookie-cutter checklists - we're talking about the real, practical inspection points that determine whether a distribution box will

Distribution Box Cost Guide 2024: Comprehensive Pricing, Features

Discover complete distribution box cost analysis including pricing factors, advanced features, safety benefits, and smart technology innovations. Get expert insights on ROI, installation costs, and long





Cost Guide for Replacing Your Septic System Distribution Box

Replacing a septic system distribution box is not just a matter of convenience; it's essential for the health of your entire septic system. Ignoring a failing distribution box can lead to

Electrical Distribution Board Inspection Form

8. Electrical Distribution Board Inspection.doc - Free download as Word Doc (.doc), PDF File (.pdf), Text File (.txt) or read online for free. (1)
This document is an



Fees table

In the event of a negative inspection, default on payment, failure to provide monthly reports or other significant breaches of the EPAL licensing terms, inspection fees will be charged for all 12

Septic Tank Distribution: All You Need to Know about

You can also look for any visible signs of the distribution box, such as a raised inspection port or vent stack. If you are still having difficulty finding the



Electrical DB Inspection Checklist , PDF

Electrical Distribution Board Inspection Checklist - Free download as Word Doc (.doc), PDF File (.pdf), Text File (.txt) or read online for free. The document is an



Distribution Box Replacement Cost Guide - Design Transition Studio

Distribution Box Replacement Cost Guide January 24, 2026 Buyers typically pay a broad range for replacing a distribution box, driven by box size, amperage, wiring runs, and local labor rates. This

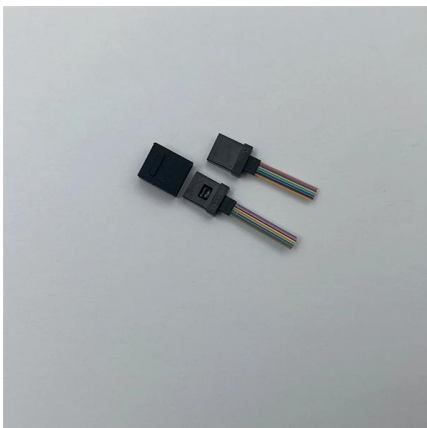

Septic Tank Distribution Box Replacement Cost Guide

In many regions, replacing a distribution box requires permits and inspections to ensure compliance with local health and safety regulations. These fees can range from:



Electrical Distribution Board Inspection Checklist

Download free electrical distribution board inspection checklist from Lumiform. Ensure safety and compliance with detailed board inspections.

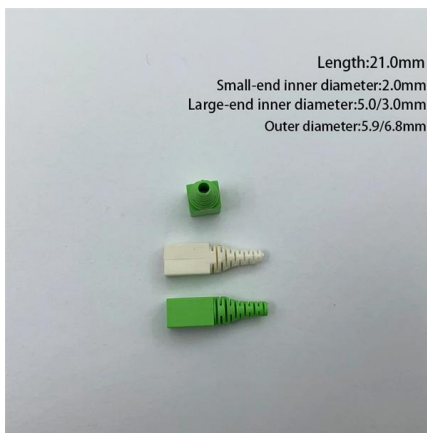

Electrical Distribution Board Inspection Checklist , PDF

Electrical Distribution Box (DB) Inspection Checklist - Free download as PDF File (.pdf), Text File (.txt) or read online for free.

On-site distribution box inspection - quote - 24/7 Emergency

On-site distribution board inspection by certified electricians. 24/7 emergency service, NEN-certified, and always a FREE quote within 24 hours. Certified electricians.

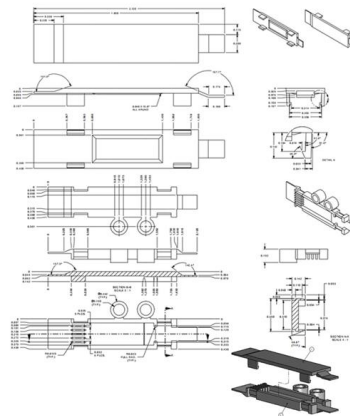

Distribution Box Replacement Cost Guide - One and Done Prep

Typical cost ranges for replacing a distribution box or service panel in the United States vary widely based on panel size, amperage, labor, and whether a full service upgrade is needed.



How Much Does Septic Distribution Box Replacement Cost?

You will need to hire a skilled plumber to replace the septic distribution cost. As such, the cost will vary depending on the rate of the plumber. On average, septic distribution box replacement

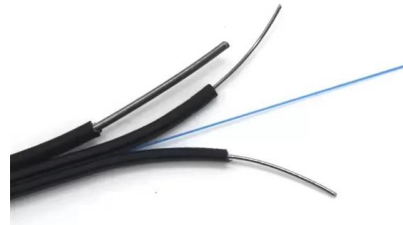

Contact Us

For datasheets, pricing, or custom telecom energy solutions, please visit:
<https://www.koskolong.co.za>