



Adam Tas Corridor Energy

Papua New Guinea Door-to-Door Shipping of Pluggable Optical Modules LPO





Papua New Guinea Door-to-Door Shipping of Pluggable Optical Mod

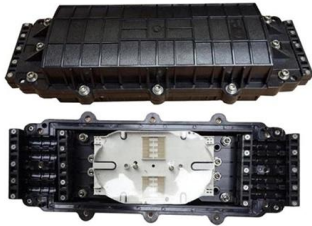

PAPUA NEW GUINEA - Import Local Charges Revision

The above charges are applicable for all container types arriving in Papua New Guinea ports on or after 1 April 2025. For further information, please contact your local Swire Shipping

International Ocean Shipping Services to Papua New Guinea , Nex

International Ocean Freight Shipping to Papua New Guinea Most efficient and cost-effective way to move items from USA to Papua New Guinea. Ocean shipping services is ideal for; Commercial



Papua New Guinea - ABAF

Door-to-Door Services in Papua New Guinea Alliance Shipping makes it easy by picking up your things from your place and bringing them right to where they need

Semtech to showcase new linear pluggable optical links

Semtech announced the demonstration of 100Gbps/lane linear pluggable optical links



featuring Semtech's PAM4 PMDs from its FiberEdge

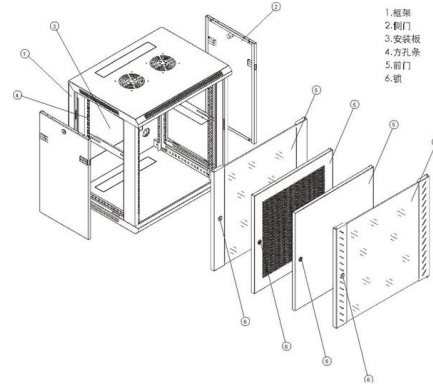

Supply chain causing major stress for Papua New

Global supply chain issues are having a major impact on many businesses in Papua New Guinea. Business leaders tell Business Advantage

Ship to PAPUA NEW GUINEA :PAPUA NEW GUINEA

This guide aims to provide you with all the information you need to know when sending a shipment to (PAPUA NEW GUINEA) using our calculation tools and



Import Procedures , Papua New Guinea Customs Service

The Master of a vessel must report all cargo details and is legally bound to "answer, to the best of his knowledge and belief, all questions"





Maritime Trade and Development in Papua New Guinea

Maritime Sector Analysis National Fleet and Ship Types PNG's national fleet grew by 10.3% in 2023 total carrying capacity of 220,000 DWT National Flag: 210 ships.



Papua New Guinea , PNG

Papua New Guinea A multi-purpose liner service accepting all types of containerized, breakbulk and project cargo connecting every 14 days the East Coast of Australia

Import Procedures , Papua New Guinea Customs Service

By law, you (the owner) are responsible for correctly declaring all goods imported into Papua New Guinea (by sea, air, or land) to Customs.

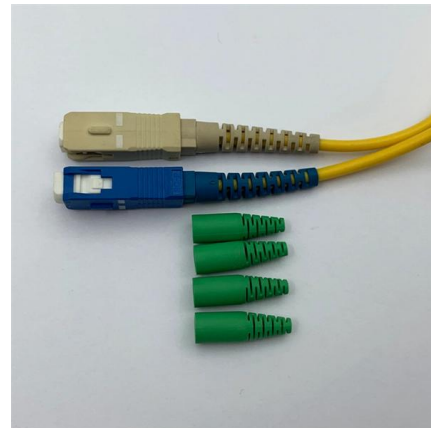

Everything You Need to Know About 800G/1.6T Optical

Explore 800G/1.6T pluggable optics: key architecture, applications, challenges, and future co-package trends.





Papua New Guinea Shipping Routes , Freight Forwarder

Papua New Guinea Shipping Routes from Europe, Africa, Australasia, North America, South America and Asia. Contact us for a free quote.



Import Procedures , Papua New Guinea Customs Service

The Master of a vessel must report all cargo details and is legally bound to "answer, to the best of his knowledge and belief, all questions" relating to the ship and its contents asked by a Customs officer.

ITS Logistics August Supply Chain Report: Tariffs Drive Mixed Impact

"More than likely, these gains will average out over the coming months." While capacity remains closely monitored by experts, fuel prices are a growing challenge across the freight industry. In one survey,



LPO MSA Announces Release of Specification for Linear Pluggable Optical

OFC2025, San Francisco -- The LPO MSA (Linear Pluggable Optics Multi-Source Agreement) Group announced today the completion and availability of the 100 Gb/s per lane Linear



Ship Supply & Chandlery Services in Papua New Guinea

Reliable and compliant ship supply in Papua New Guinea is essential to ensure vessel efficiency, crew welfare, and seamless logistics in this geographically diverse and challenging environment.

Length:33.5mm
Small-end inner diameter:4.0mm
Large-end inner diameter:6.0mm



Papua New Guinea's Top Exports 2024

Papua New Guinea's Top 10 Exports The following export product groups represent the highest dollar value in Papua New Guinean global shipments during 2024.

Freightways PNG , Logistics & Freight Forwarding in Papua New Guinea

With over 25 years of combined experience, we specialize in navigating the Pacific region's unique challenges - from remote highlands delivery to complex customs clearance.





Ship to PAPUA NEW GUINEA :PAPUA NEW GUINEA

PAPUA NEW GUINEA Tariffs and Value Added Tax Guide Tariffs refer to the taxes levied by PAPUA NEW GUINEA on goods entering or leaving its borders in



Semtech to Demonstrate 100G/Lane Linear Pluggable

800G SR8 LPO (Linear Pluggable Optics) module, featuring Semtech's FiberEdge GN1848 quad VCSEL driver and GN1816 quad TIA, interoperating



Shipping To Papua New Guinea [eCommerce Guide]

Discover a guide to shipping to Papua New Guinea, with times, incoterms, customs clearance and solutions.

Shipping Cargo to Papua New Guinea

Alliance Shipping offers reliable and cost-effective Shipping cargo to Papua New Guinea services, including sea freight, air freight, and door-to-door delivery.



For Importers - National Trade Portal

Papua New Guinea imports a range of electrical machinery and equipment, including computers, telecommunications equipment, and electrical components. The majority of Papua New Guinea's

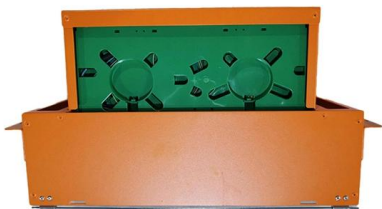

For Importers - National Trade Portal

Import Procedures for Papua New Guinea? The National Trade Office is the Papua New Guinean government's trade and investment development agency, and has no involvement in the import



International Shipping Services to Papua New Guinea , Nex

Door-to-Door parcel shipping with Express, Economy and Saver service options. 1 to 5 days delivery to Papua New Guinea. Ideal for shipping envelopes, packs, small packages and boxes up to 250 lbs.





Import Procedures , Papua New Guinea

By law, you (the owner) are responsible for correctly declaring all goods imported into Papua New Guinea (by sea, air, or land) to Customs.



Contact Us

For datasheets, pricing, or custom telecom energy solutions, please visit:
<https://www.koskolong.co.za>