

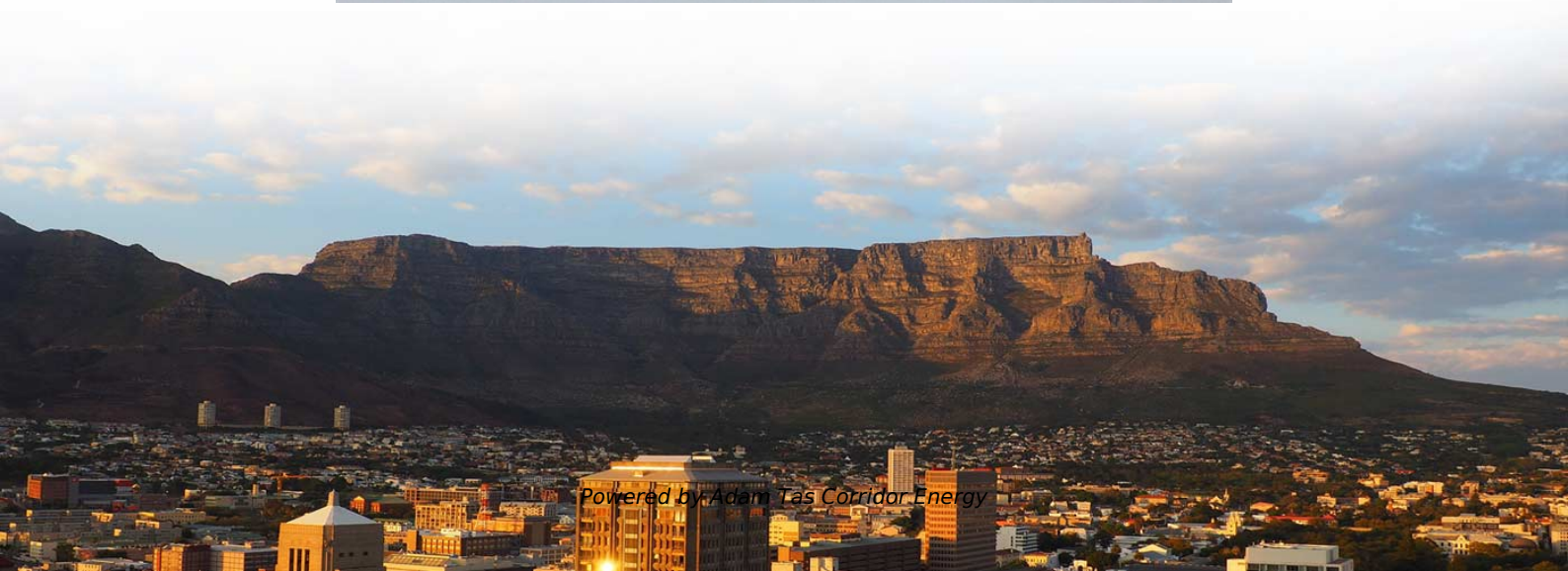

Adam Tas Corridor Energy

Relay protection device identification code





Overview

This table details ANSI IEEE Standard Device Numbers as used for protective relaying in North America. The protection and control devices in electrical equipment can be referred to by numbers, with appropriate suffix letters when necessary, according to the functions they perform. These numbers are based on a system that is adopted by a standard for automatic switchgear by Institute of Electrical.



Relay protection device identification code

ANSI device numbers

In electric power systems and industrial automation, ANSI Device Numbers can be used to identify equipment and devices in a system such as relays, circuit breakers, or instruments. The device



ANSI Codes

Device Numbers 1. Master Element is the initiating device, such as a control switch, voltage relay, float switch, etc., which serves either directly or through such permissive devices as protective and time



Relay and Device Number List

The document lists over 100 device numbers and acronyms used for protective relays and devices in power systems. The numbers and acronyms provide



A Guide to ANSI/IEEE Function Numbers

These numerical codes, ranging from 1 to 99, uniquely identify the functions of protective



relays, associated devices, and control equipment in



Protection Relay

In the design of electrical power systems, the ANSI Standard Device Numbers denote what features a protective device supports (such as a relay or

Table of ANSI IEEE Standard Device Numbers

This table details ANSI IEEE Standard Device Numbers as used for protective relaying in North America. Suffixes for numbers are also suggested.

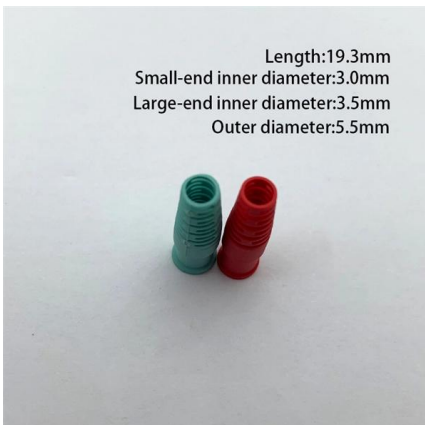

ANSI Protective Device Numbering Guide , PDF , Relay

It provides a comprehensive list of the standard device numbers (such as 51 for time overcurrent relay and 50 for instantaneous overcurrent) and explains how



IEC Protection Relay Codes PDF

IEC Protection relay Codes.pdf - Free download as PDF File (.pdf), Text File (.txt) or read online for free.

5-INCH COLOR TOUCHSCREEN

Intuitive operation, easily accessible with just one touch



To: [Customer Name]

ANSI/IEEE Standard Device Numbers In North America protective relays are generally referred to by standard device numbers. Letters are sometimes added to specify the application (IEEE Standard

ANSI Device Numbers and Acronyms

The ANSI standard device numbers (As per ANSI/IEEE standard C37.2) are used in the design of an electrical power system. These devices



ANSI codes and IEC Relay Symbols - Electrical

To assist the Protection Engineer in converting from one system to the other, a select list of ANSI device numbers and their IEC equivalents are given in the following



ANSI codes and IEC Relay Symbols - Electrical

There are two methods for indicating protection relay functions in common use. One is given in ANSI Standard and uses a numbering system for various functions.



Relay symbols and device numbers; selection from IEC 617-, IEEE

Definition and function Master element is the initiating device, such as a control switch, voltage relay, float switch etc., that serves either directly, or through such permissive devices as protective and

ANSI Codes for Protection Devices , PDF , Relay , Switch

This document lists ANSI device numbers and acronyms for protection devices used in power systems. It provides a table with two columns - the first column lists





ANSI Relay Numbers PDF , Download Free Guide

ANSI Relay Numbers are standardized codes identifying protective devices in electrical systems, ensuring clarity and efficiency in system design and

ANSI Standard Device Numbers & Common Acronyms

ANSI Standard Device Numbers & Common Acronyms
ANSI Standard Device Numbers & Common Acronyms

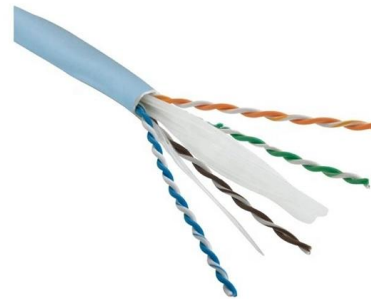

ANSI Codes for Relay Devices , PDF , Relay , Switch

Device codes in bold are most commonly used. Codes 1 through 100 are defined, with the most frequently referenced codes pertaining to master elements, time

ANSI/IEEE Relay Protection Codes Guide

This document lists standard device numbers for protective relays used in North America according to ANSI/IEEE Standard C37.2-2008. The numbers are used to refer to different types of relays, with the



Protection and Control Device Numbers and Functions

The protection and control devices in electrical equipment can be referred to by numbers, with appropriate suffix letters when necessary, according to the functions they perform.



ANSI (IEEE) Protective Device Numbering

Protective relays are commonly referred to by standard device numbers. For example, a time overcurrent relay is designated a 51 device, while an instantaneous overcurrent is a 50 device.



ANSI Device Numbers List , PDF , Relay , Switch

Master Protection code - ANSI - Free download as PDF File (.pdf), Text File (.txt) or read online for free. The document lists ANSI device numbers and their

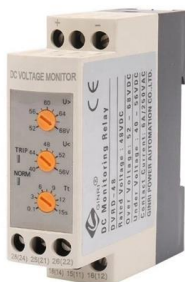



ANSI/IEEE Relay Protection Codes

This document lists ANSI/IEEE protection codes that are used to identify different types of protective relay devices and monitoring equipment. There are over 100



ANSI/IEEE Relay Device Numbers List

ANSI/IEEE Relay Device Numbers List This document lists standard device numbers for protective relays used in North America according to ANSI/IEEE Standard

ANSI Device Numbers Overview , PDF , Relay

ANSI device numbers standardize the identification and operation of protective and control devices across electrical systems, ensuring consistency,



Relay Protection Device Codes List , PDF , Relay , Switch

Relay Protection Device Codes List The document outlines standard device numbers for protective relays, such as 50 for instantaneous overcurrent and 51 for time



ANSI Device Numbers and Acronyms Guide

This document lists ANSI standard device numbers and common acronyms used in power systems. It provides suffixes and descriptions for device numbers

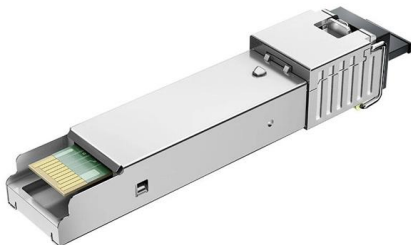
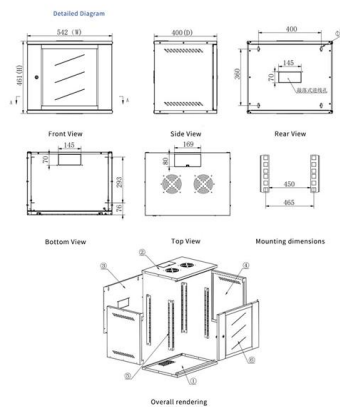

Understanding the ANSI/IEEE Device Numbering System

The American National Standards Institute (ANSI) and the Institute of Electrical and Electronics Engineers (IEEE) device numbering system provides a standardized language for

Contact Us

For datasheets, pricing, or custom telecom energy solutions, please visit:
<https://www.koskolong.co.za>