



Adam Tas Corridor Energy

Self-provided power distribution box





Self-provided power distribution box



Temporary power distribution box DE 63 A

For your power connections on a building site. Ask us about the possibilities for the utility connections on your building site. All rates excl. 19% VAT.

Understanding Distribution Boxes: A Comprehensive Guide

A distribution box, also known as a power distribution box or electrical distribution box, is used to distribute electrical power safely to multiple

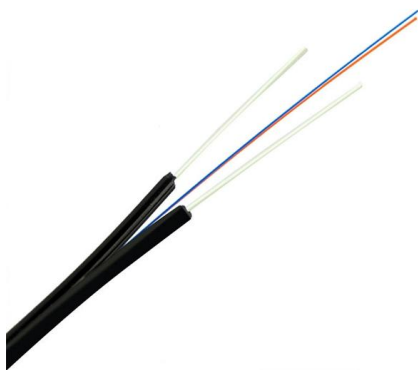

Best Generator Power Distribution Boxes for Temporary and

Power distribution is essential when working with generators, especially for construction sites, outdoor events, and home backup power setups. Choosing the right generator power

Custom Power Distribution Box Manufacturers , J& HW

Discover reliable power distribution box manufacturers and custom power distribution



solutions for every need.

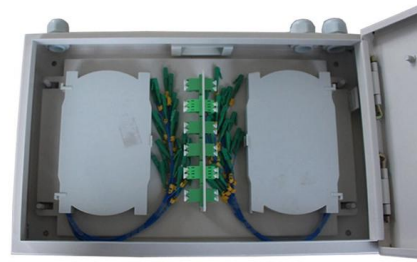

what is a temporary power distribution box?

Understanding Temporary Power Distribution Boxes A temporary power distribution box is a portable device designed to distribute electrical power

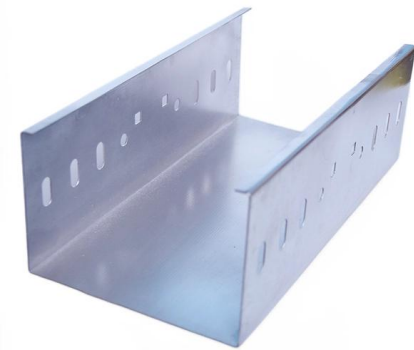

Temporary Power Distribution Boxes

Get the power you need with Southwire's high-quality temporary power distribution boxes.



PowerBox Factory

PowerBox factory offers a vast range of PDUs, distro boxes, racks, panels, adapters, cable extensions and splitters to safely manage power distribution, all designed and built to be fully compliant with the





50A, 120/240V AC Temporary Power Distribution System Boxes

Hubbell Distribution Boxes, 50A, 120/240V AC
Time is money and since a lack of power can cost time, having the ability to stay connected with temporary power is crucial. Thus the temporary power



The Ultimate Guide to Distribution Box Types

Discover the key types of distribution boxes with NUOMAK's comprehensive guide. Learn about Main Distribution Boards (MDB), Consumer Units, Transfer

What is a Distribution Box? - A Comprehensive Guide

A distribution box organizes and controls power flow, ensuring safety and efficiency in electrical systems.



Power Distribution Boxes

Our boxes support both single-phase and three-phase power distribution, making them ideal for industrial, commercial, and construction applications. All units are



Power distribution boxes - safe site power distribution , Modipro

Power distribution boxes for safe and flexible power supply on sites and workshops. Designed for heavy tools and multiple circuits. In stock now.

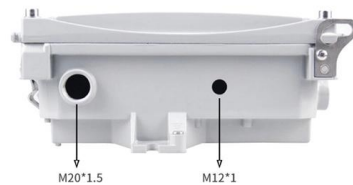

Portable PDUs , Shop Spider Boxes, Power Distribution Boxes & More

Affordable, reliable portable power distribution units for installation in any job location. Explore the full selection today.



Temporary Power Distribution Boxes for Electrical

Temporary power distribution boxes for flexible electrical installation. Robust solutions for construction sites, events and temporary energy infrastructure.



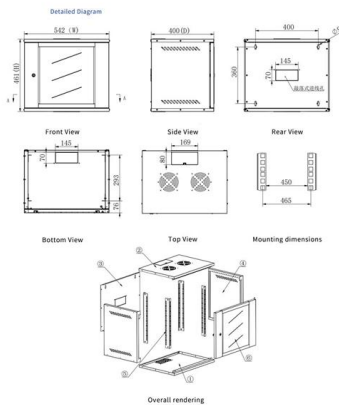

Distribution Boxes Explained: Types, Functions, and

Learn about distribution boxes, their types, functions, and safety features to ensure efficient and secure electrical power distribution in any building.

Portable Power Distribution Units & Boxes, LEX Products

Portable Power Distribution Boxes: PowerHOUSE (TM) & PowerRACK (TM) Lex Products offers a full range of portable power distribution boxes



A Guide to Temporary Power Distribution Boxes , ATI

Temporary power distribution boxes are a popular method of providing electrical power to remote areas. Learn about the benefits of using

Power Distribution Boxes

Explore our Power Distribution Boxes! Enjoy factory-direct sales and expert customization for efficient power management. Shop now for reliable solutions.

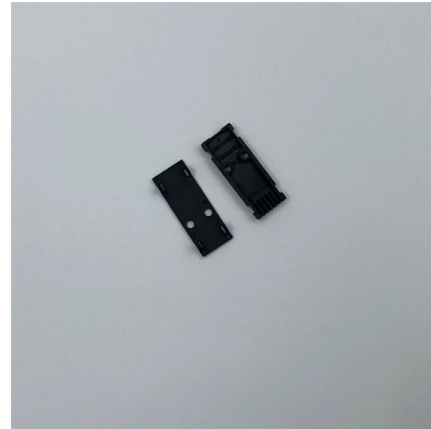

Portable Power Distribution Systems

Each portable power distribution box is inspected and tested in accordance with EN 60 439-1; 1994 table 7, A copy of the test certificate is provided with each unit.



Power Distribution Box Essentials: Functions, Types

7) Considerations for choosing a power distribution box The context, security needs, and purpose all play a vital role in deciding a power distribution



The Ultimate Guide to Temporary Power Distribution Boxes

Learn all about temporary power distribution boxes, their applications, advantages, and how to choose the right one for your needs.





What does a power distribution box do ?

The main function of the distribution box is to receive power and distribute it to various circuits. It can protect circuits, regulate voltage, and isolate and control



Electrical Distribution Boxes for Power Distribution , Wieland

Electrical distribution boxes for modular power distribution and installation. Flexible distribution solutions for industrial and building electrical infrastructure.

Power Distribution Boxes

Reliable power distribution boxes designed for safety and efficiency--perfect for industrial and commercial setups.



Contact Us

For datasheets, pricing, or custom telecom energy solutions, please visit:
<https://www.koskolong.co.za>