



Adam Tas Corridor Energy

Surface-mounted outdoor lighting distribution box





Overview

Choosing the right surface mount electrical box is essential for safe, code-compliant outdoor and indoor lighting installations. It is robust and waterproof to effectively protect your electrical components from moisture, rain and other weather influences. Various versions of distribution boxes, a large selection of materials, voltage ranges, rated currents and IP protection types / protection classes for indoor and outdoor use, as well as a wide range of accessories and tools such as WAGO plug-in terminals, crimping tools, cable ties, wire end. Ideal for indoor control cabinets or small outdoor distribution points, it reduces fire risks from circuit faults. With IP65 protection (dust-tight, low-pressure water-resistant), it suits outdoor scenarios like garden power distribution, outdoor lighting control, and garden equipment power supply.



Surface-mounted outdoor lighting distribution box



Surface-Mounted Distribution Box, IP65 Waterproof Fuse Box, Surface

Waterproof and durable: the wall mounted distribution box carries the IP65 certificate, making it ideal for outdoor use. Its robust construction ensures durability and protection from the

Surface mounted distribution box, IP 65 - Distribution box

Distribution box, surface mount, transparent door, N/PE rail 1×4 mod, H×W×D=210.3×142.8×99.5mm, IP65,1000 VAC, 1500 VDC



17MDEP 5KW.1PH.OUTDOOR STREET LIGHT

Buy 17MDEP 5KW.1PH.OUTDOOR STREET LIGHT CONTROL PANEL BOX Distribution Board for Rs.15500 online. 17MDEP 5KW.1PH.OUTDOOR STREET



Arelos Surface electrical Distribution Boxes , Solera

Discover Solera's Arelos surface-mounted distribution boxes, available from 2 to 56



modules, with smoked door options and durable IP40 and IK08 design.



Outdoor Cut Outs and Distribution Boxes

Our Products Lucy Electric's range of low voltage outdoor cut outs and distribution boxes is engineered for durability, safety, and ease of installation in demanding



Amazon : Surface Mount Electrical Box: Tools & Home Improvement

1-24 of over 2,000 results for "surface mount electrical box" Results Check each product page for other buying options.



IEC60439-3 Surface Mounted 100A Outdoor Db Box

High quality IEC60439-3 Surface Mounted 100A Outdoor Db Box from China, China's leading product market surface mounted outdoor db box product, with

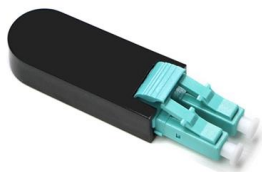



IEC60439-3 Surface Mounted 100A Outdoor Db Box

High quality IEC60439-3 Surface Mounted 100A Outdoor Db Box from China, China's leading surface mounted outdoor db box product, with strict quality

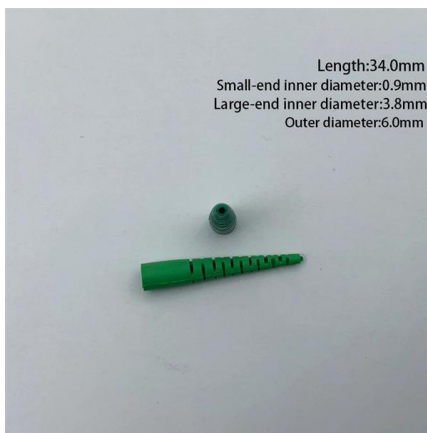

Flat Surface Mounting Kit with Built-in Box (single Pack)

This mounting block has a built-in electrical box, so you would not mount it to another weatherproof box. It is designed to be mounted directly to a flat surface like siding

Surface Distribution Sealed Boxes , Solera

Solera's surface-mounted boxes provide durable protection for electrical installations in industrial environments. 3 to 15 modules: Wide range of sizes for all setups.



Distribution Box Specs

Product Description Our distribution box serves as a connection and branching box which can be used outdoors. It performs well in wet locations with the water-proof rating of IP66. With the maximum



Leviton Surface Mount Backbox, Single Gang, 1.89", 42777-1WA

Leviton QuickPort housings, such as wall plates, MOS housings and modular furniture faceplates, can be configured with a custom combination of QuickPort modules which easily snap in or out of ports.



IP65 WHA Plastic Distribution Box Surface Mounted

Ideal for indoor control cabinets or small outdoor distribution points, it reduces fire risks from circuit faults. With IP65 protection (dust-tight, low-pressure water)

Surface mounted Outdoor Wall Lighting

I have a customer/ friends brother who wants four outdoor wall lights installed in the back and side of his house. These will be surface mounted on stucco. There is one existing light that will





Surface Mount Outdoor Electrical Distribution Box

We're professional surface mount outdoor electrical distribution box manufacturers and suppliers in China, specialized in providing the best customized service. If

Sicherungskasten

Various versions of distribution boxes, a large selection of materials, voltage ranges, rated currents and IP protection types / protection classes for indoor and outdoor use, as well as a wide range of

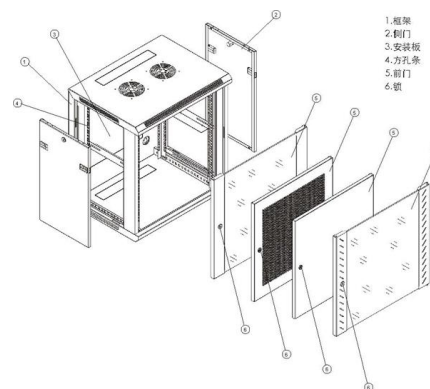

Leviton Surface Mount Backbox, Dual Gang, 1.89"

Leviton QuickPort housings, such as wall plates, MOS housings and modular furniture faceplates, can be configured with a custom combination of QuickPort

Surface-Mount Outdoor LED Ceiling Lights by Alcon

Performance and Durability for Exterior Ceiling Applications Designed for high-performance outdoor lighting, Alcon Lighting's surface-mount LED ceiling fixtures





Surface mounted distribution box, IP 65 - Distribution box

Distribution box, surface mount, transparent door, N/PE rail 1x15 mod, HxWxD=197.5x310x106mm, IP65, 1000 VAC, 1500 VDC Net34.40000 EUR Gross43.68800 EUR Comparison Ordering in

Lighting Distribution Boxes for Power Control

Our comprehensive Lighting Distribution Boxes are essential components for professional electricians working with Lighting, Lamps & Tubes installations. Whether you're installing LED Lamps, LED



Surface-Mounted Distribution Box, IP65 Waterproof Fuse Box, Ideal

Practical surface mounting: with its surface-mounted installation, the distribution box is easy to install and allows convenient access to the modules contained in it. It is perfect for use in gardens, outdoor

Waterproof Distribution Box , IP65 Plastic DIN Rail

Each enclosure delivers dependable IP65-IP68 sealing for outdoor and industrial use, with options for plastic waterproof distribution box housings and DIN rail



Surface-mounted electrical distribution panels , boxes

Overhead plastic electrical distribution panels with IP65, IP66, and IP67 standards are the ideal solution for anyone looking for high-quality, reliable, and durable



Discover Europe's digital cultural heritage , Europeana

Hier sollte eine Beschreibung angezeigt werden, diese Seite lässt dies jedoch nicht zu.

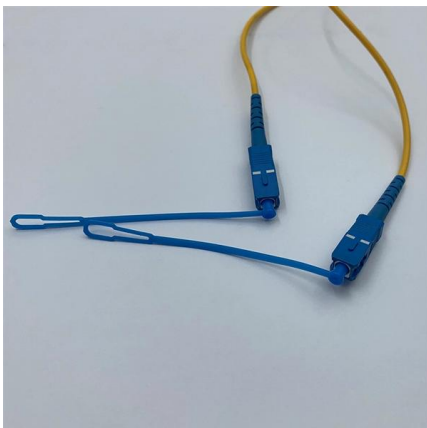

Sicherungskasten

Whether you are looking for a set of components for the control of industrial systems or material for safe power distribution and reliable electrical installation in the hobby garage.



Best Surface Mount Electrical Boxes for Light Fixtures

Choosing the right surface mount electrical box is essential for safe, code-compliant outdoor and indoor lighting installations. This guide highlights top

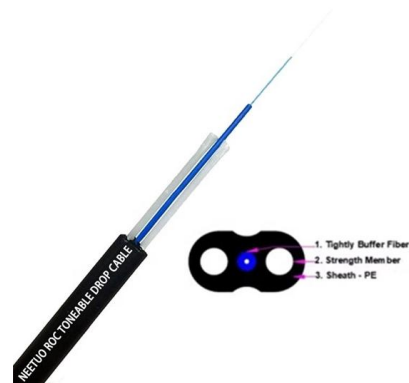

Contact Us

For datasheets, pricing, or custom telecom energy solutions, please visit:
<https://www.koskolong.co.za>