

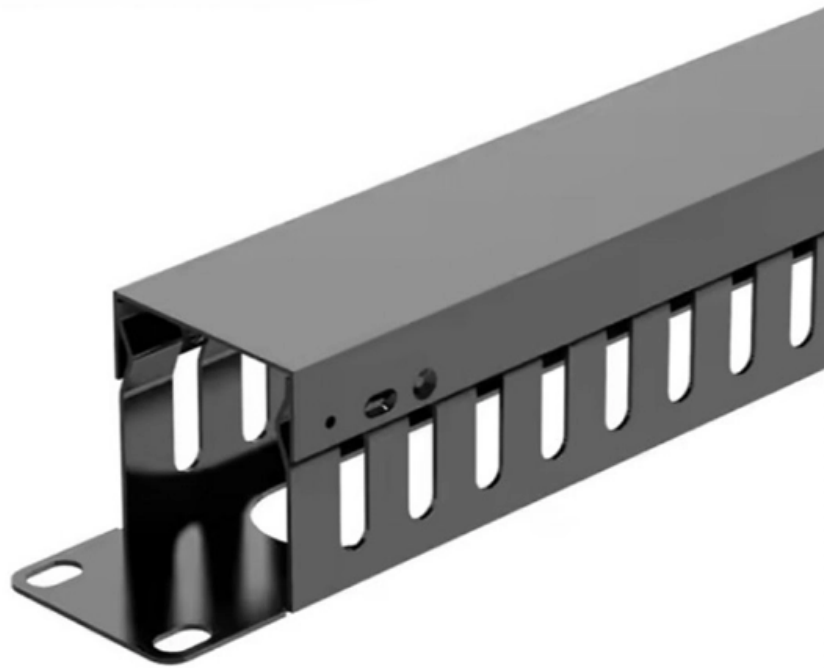

**Adam Tas Corridor Energy**

# **The supercomputing center uses a 800G vertical-cavity surface-emitting laser from Bosnia and Herzegovina**





## The supercomputing center uses a 800G vertical-cavity surface-emitting

---



### **(PDF) High-power vertical-cavity surface-emitting arrays**

The vertical-cavity surface-emitting laser technology (VCSEL) presents an attractive alternative as a high-power semiconductor laser source

### **Modeling and simulation of vertical-cavity surface-emitting lasers**

Despite their low manufacturing costs, diffraction-limited, narrow-band emission and excellent modulation capability, VCSELs were only used for optical data transmission and sensor technology



### **Vertical Cavity Surface Emitting Lasers (VCSELs):**

A specific photonics technology that shows great promise for high speed intra-satellite data transfer applications is the Vertical Cavity Surface Emitting Laser diode (VCSEL). It is a semiconductor

### **Vertical Cavity Surface-emitting Lasers**

Vertical cavity surface-emitting lasers (VCSELs) are a monolithic kind of semiconductor lasers



with beam emission perpendicular to the wafer surface.

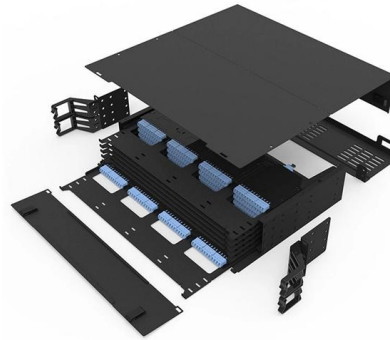

### Vertical-Cavity Surface-Emitting Lasers for Miniature

1 INTRODUCTION Semiconductor vertical-cavity surface-emitting lasers (VCSELs) [1 - 5] are one of the key elements of modern and perspective optical information systems, which is due

### Understanding Vertical-Cavity Surface-Emitting Lasers

A Vertical-Cavity Surface-Emitting Laser (VCSEL) is a type of semiconductor-based laser diode that emits light perpendicular from its top



- IP65/IP55 OUTDOOR CABINET
- OUTDOOR MODULE CABINET
- OUTDOOR 5G BASE STATION CABINET
- WATERPROOF

### Vertical cavity surface-emitting semiconductor laser with CW injection

Room-temperature CW operation of a GaAs/AlGaAs vertical cavity surface-emitting laser with a resonant periodic gain medium, using a GaAs/AlGaAs diode laser array as a pump source, is



## Antireflective vertical-cavity surface-emitting laser for LiDAR

The authors showcase an innovative anti-reflective vertical-cavity surface-emitting laser (AR-VCSEL) that achieves low divergence and maintains a single-mode lasing. The 6-junction AR



## High-Speed Vertical-Cavity Surface-Emitting Laser

This paper reviews device design and performance of high-speed vertical cavity surface emitting laser (VCSEL) arrays for next-generation short

## Vertical-cavity surface-emitting laser operating with photonic crystal

A vertical-cavity surface-emitting laser with a two-dimensional photonic crystal (PC) structure has been investigated for single lateral mode operation. The PC confined mode can be



## Optically-pumped vertical-external-cavity surface-emitting

The optically-pumped vertical-external-cavity surface-emitting semiconductor laser (OP-VECSEL) is a versatile laser source that can generate high average power in a circular diffraction



### Vertical cavity surface emitting lasers (VCSELs)

Abstract: The semiconductor vertical cavity surface emitting laser (VCSEL) diode is introduced and the dominant applications that use the nearly one billion VCSELs that have been deployed world-wide

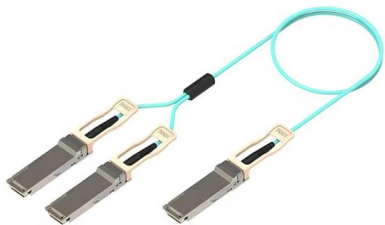

### Giant cavity surface-emitting laser for high-brightness

In this study, we demonstrate an unprecedented design of giant cavity surface-emitting laser with an ultrasmall divergence angle and a high brightness

### Vertical-cavity surface-emitting laser

Its unique vertical emission structure, low power consumption, scalability, and high reliability make it indispensable across industries ranging from data communications to automotive





## Study of fabrication and characterization of high power 850 nm vertical



In this paper, we investigated high power selectively oxidation-confined Al x Ga 1-xAs/GaAs 850 nm vertical-cavity surface-emitting laser (VCSEL) and fabricated two-dimensional

## Vertical-Cavity Surface-Emitting Lasers and Their Applications

A notable breakthrough in VCSEL technology is the demonstration of multi-junction cascaded devices that exhibit power conversion efficiencies exceeding traditional edge-emitting lasers.

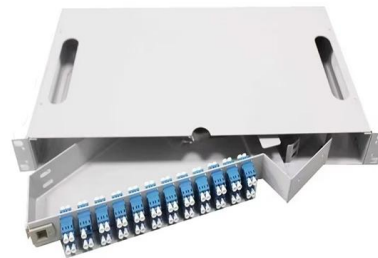

## Vertical-cavity surface-emitting lasers: the applications

In this paper, we focus on how vertical-cavity surface-emitting lasers (VCSELs) and arrays have led to many feasible advanced technological applications. Their intrinsic characteristics,

## Vertical external cavity surface emitting laser

Optical pumped semiconductor disk lasers (VECSEL) with an external cavity allow for high output power scaled by the pump beam. In this layer design the upper DBR is replaced by an external mirror.





## Physics of the Gain Medium in Vertical-Cavity Surface-Emitting

Abstract Vertical-cavity surface-emitting lasers (VCSELs) have been the subject of research and development for over two decades [1,2]. These lasers have evolved from laboratory curiosities, to

## Dynamical and Thermal Properties Muayad Abusaa

Abstract Vertical cavity surface emitting laser diodes (VCSELs) are widely used in different areas especially in telecommunications because of their unique properties compared to other types of



## Design and simulation of 850 nm InGaAs QWs vertical

This work presents a comprehensive numerical simulation and analysis of vertical cavity surface emitting lasers (VCSELs) at room temperature.

## Thermal Management of High-Power Vertical-Cavity Surface-Emitting Laser

Vertical-cavity surface-emitting lasers (VCSELs) have been widely used in short-reach optical communication links and interconnects because of their high modulation speed and low



### Low-Noise, Single-Polarized, and High-Speed Vertical-Cavity Surface

A novel technique is demonstrated for suppressing the relative intensity noise (RIN) and enhancing the high-speed transmission performance of 850 nm vertical-cavity surface emitting lasers

### Vertical-Cavity Surface-Emitting Lasers XXIX , (2025)

Vertical-cavity surface-emitting lasers (VCSELs) operating at 1130 nm with single-mode characteristics are used in a variety of optical applications. In this study, we the first present to

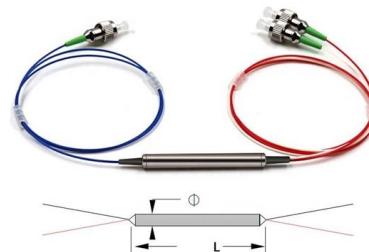

### Defect localization in high-power vertical cavity surface emitting

Applying a reverse bias near the breakdown voltage results in photon emission at the pn-junction in vertical cavity surface emitting lasers (VCSELs). This radiation can be collected with an





## High-power vertical-cavity surface-emitting lasers for solid-state

Vertical-cavity surface-emitting lasers (VCSELs) have emerged as a promising candidate for pumping of solid-state lasers, as they can be configured into high-power two-dimensional arrays



## High power density and temperature stable vertical-cavity surface

We report on the design and fabrication of high power density vertical-cavity surface-emitting laser (VCSEL) with ring close packing structure (RCP) emitting at 808 nm. The RCP

## Beyond the bifurcation scenarios in vertical-cavity surface-emitting

We study the dynamic behavior in a vertical-cavity surface-emitting laser subject to orthogonal optical injection through the computation of Lyapunov exponents and isospikes for a wide



## 795 nm high temperature and high power operating vertical-cavity

State-of-the-art vertical-cavity surface-emitting laser (VCSEL) technology will be reviewed in terms of power consumption and reliability to realize the energy-efficient high-performance



### High-Speed Semiconductor Vertical-Cavity Surface-Emitting Lasers

The main problems of providing a high-speed operation semiconductor lasers with a vertical microcavity (so-called "vertical-cavity surface-emitting lasers") under amplitude modulation



### High-speed 850 nm oxide-confined vertical-cavity surface-emitting

1. Introduction Vertical-cavity surface-emitting lasers (VCSELs) are the key laser sources for short-reach optical interconnects since VCSELs have many advantages, such as low cost, small footprint, low



### High-Power Vertical External-Cavity Surface-Emitting Lasers

Often transparent intra cavity heat spreaders bonded to the surface and/or substrate removal techniques are employed to improve gain-chip heat-removal characteristics. Multi gain-chip





## Densely packed 1.1 mm band vertical cavity surface emitting laser

We demonstrated the 1.1 mm band 16-channel vertical cavity surface emitting laser (VCSEL) array for multi-core fiber (MCF) transmission towards co-packaged optics. Single-mode 16

## Understanding Vertical-Cavity Surface-Emitting Lasers

This article focuses on the definition, working principle, benefits, limitations, and applications of Vertical-Cavity Surface-Emitting Laser (VCSEL).



## Contact Us

---

For datasheets, pricing, or custom telecom energy solutions, please visit:  
<https://www.koskolong.co.za>