

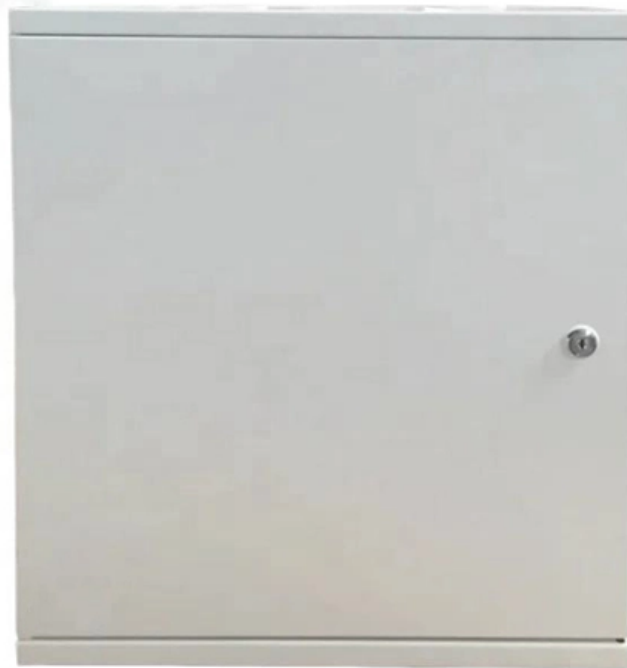

Adam Tas Corridor Energy

What are the main classification methods for electrical distribution boxes





Overview

Distribution boxes can be broadly categorized by their voltage level, application environment, and primary function. A distribution box, also known as a power distribution box or electrical distribution box, is used to distribute electrical power safely to multiple circuits. We'll chat about what each one does, where it shines, and then dive into how to choose the perfect box for your needs.



What are the main classification methods for electrical distribution



Understanding Distribution Boxes: A Comprehensive Guide

Distribution boxes can be classified in different ways depending on the installation environment, enclosure material, and mounting method. In practical projects, these categories are

Panelboards and Distribution Panels: What They Are

Introduction Navigating the world of electrical distribution can be confusing, with terms like panelboard, switchboard, and distribution box often



The Complete Guide to Distribution Box: Installation, Types & More

What's the difference between a distribution box and a sub-panel? A distribution box typically refers to the main electrical panel that receives power from the utility service. A sub-panel is



Distribution Box: Types and Functions , Axis-Electricals

A distribution box ensures that electrical supply is distributed in the building, also known as a



distribution board, panel board, breaker panel, or electric panel.

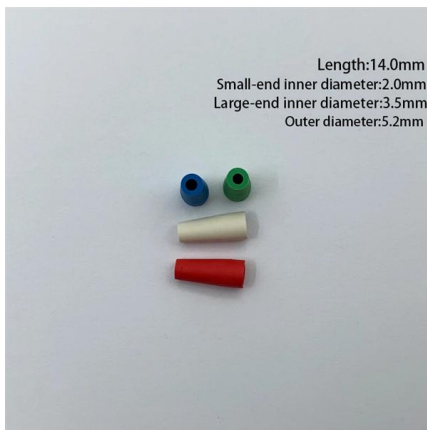

WORLD WIDE WEB JOURNAL Home

will open to start the export process. The process may take but once it finishes a file will be downloadable from your browser. You may continue to browse the DL while the export process is in

Distribution Boxes Types - The Complete Guide

The power distribution boxes deliver electricity from the main electrical main to other circuits. Several distribution boxes are designed for specific use in

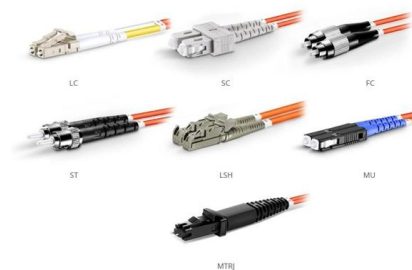

OM1 Fiber Patch Cable Family

What are the types of distribution boxes?

Distribution boxes can be broadly categorized by their voltage level, application environment, and primary function. The two most fundamental distinctions are between Low-Voltage





What is a Distribution Box? - A Comprehensive Guide

A distribution box organizes and controls power flow, ensuring safety and efficiency in electrical systems.



What Is an Electrical Distribution Box? A Complete Guide

An electrical distribution box is a centralized unit responsible for distributing electrical power across multiple circuits within various

What Are the Main Materials Used in Distribution Boxes

Basic Function A distribution box is very important in an electrical system. It sends electricity from the main supply to different circuits. This keeps your power neat

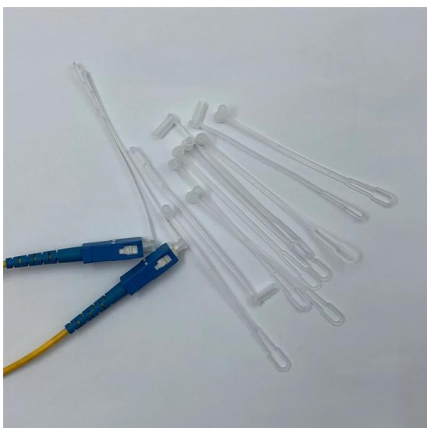

Distribution Boxes Explained: Types, Functions, and

Learn about distribution boxes, their types, functions, and safety features to ensure efficient and secure electrical power distribution in any building.



A Definitive Guide To Distribution Boxes

The distribution box acts as the center of power distribution, distributing electricity to all connected devices. A distribution box, also known as a distribution board, panel board, breaker

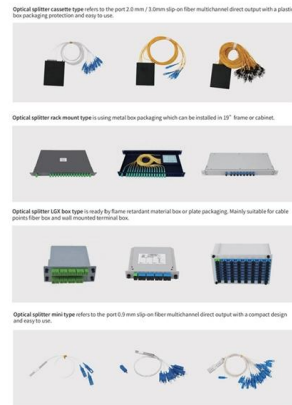

Distribution Box Industry Comparison of Types and Uses

Compare types and uses of distribution boxes in the distribution box industry, covering residential, commercial, and industrial applications.

Distribution Boxes: Types and Functions

Learn what an electrical distribution box (DB/distribution board) is, its main components (MCB/RCCB/RCBO, SPD, busbar) and common types.



Electrical Distribution Boxes: Types, Uses & Selection

Learn how electrical distribution boxes work, their key components, common types, and how to choose the right enclosure for safe and reliable power distribution.



Ultimate Guide To Distribution Boxes Db Boxes Types

Introduction For procurement professionals, electrical contractors, and project managers, choosing the right Distribution Box (DB Box) is a critical decision that



Electrical Distribution Box: Complete Panel Types Guide

Learn what an electrical distribution box is in simple terms. Complete guide to panel types, NEC 408 requirements, and applications for home and

Electrical Distribution Boxes: Types, Uses & Selection

Types of electrical distribution boxes are typically classified by function and by application to align enclosure selection with system architecture and applicable

DETAILS DISPLAY

Focus On Every Detail



01

Neat & Clean Layout

Cleaner arrangement of components. Easy to operate



Understanding Distribution Boxes:A Comprehensive Guide

Understanding its significance, this article covers what a distribution box is, how it functions, its structure, the various types available, and how it

The Ultimate Guide to Distribution Box Types

Discover the key types of distribution boxes with NUOMAK's comprehensive guide. Learn about Main Distribution Boards (MDB), Consumer Units, Transfer



Ultimate Guide To Distribution Boxes Db Boxes Types

This ultimate guide explains what a distribution box does, its internal components, common types, real-world applications, and how to select the right DB Box for

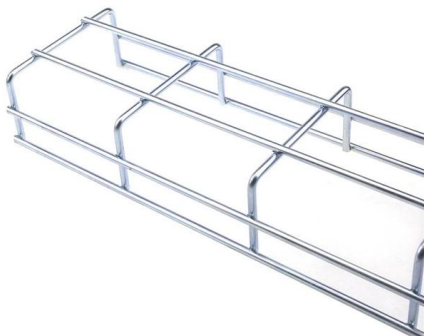

12 types of distribution boxes and how to choose them

In this guide, we'll break down the 12 main types of distribution boxes in a way that's easy to understand. We'll chat about what each one does, where it shines, and then dive into how to choose the perfect



The Importance of Distribution Boxes in Electrical Systems

Learn more about how distribution boxes play a critical role in the safe and efficient operation of electrical systems.



Complete Guide For Distribution Boxes Types

By understanding the specific requirements and characteristics of each type of distribution box, electrical engineers, contractors, and homeowners can make



The Meaning and Function of Primary, Secondary, and Tertiary

Follows the principle of "one machine, one switch, one RCD, one box, one lock," ensuring no single switch controls multiple devices. This explanation aims to clarify the roles and functions of





1. An Ultimate Guide for Metal Distribution Boxes

1) Metal Distribution Boxes Constructed from steel, aluminum, or cast iron, metal distribution boxes are highly durable and resistant to mechanical damage. Ideal



Contact Us

For datasheets, pricing, or custom telecom energy solutions, please visit:
<https://www.koskolong.co.za>