

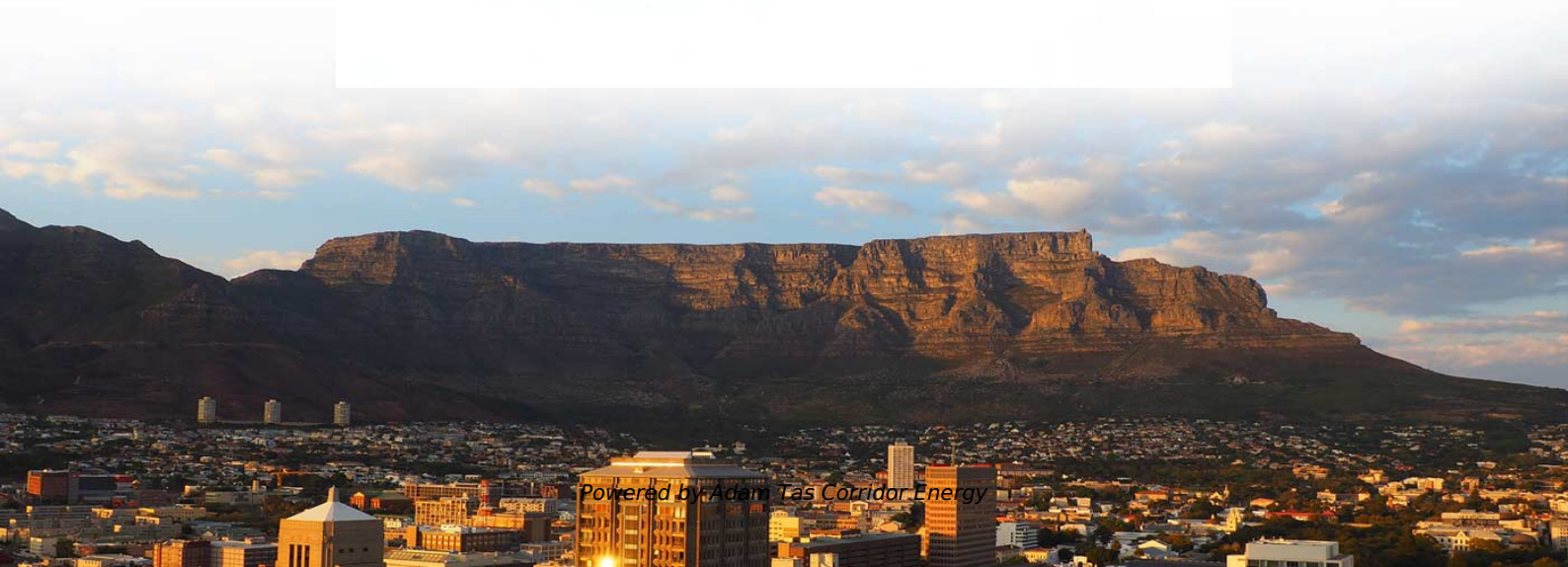

Adam Tas Corridor Energy

Which Australian flame-retardant cable tray manufacturer is the best





Which Australian flame-retardant cable tray manufacturer is the best?



100+ Essential Questions Answered About Cable Trays:

Discover over 100 expert answers about cable trays, covering key topics like material selection, load capacity, installation methods, and maintenance.

AS/NZS3013:2005 FIRE RATED CABLE MANAGEMENT

We now have a NEW range of fire rated cantilever assemblies for cable ladder and ET3 cable tray; expanding your choice when it comes to supporting your cables. Refer to the handy comparison

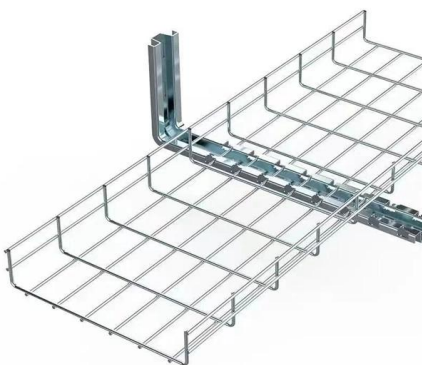

Fire Rated Cable Support Systems

Burndy is an Australian owned and operated company. Our products are Australian made to Australian standards. Pioneers of the original Laddertray systems, Burndy are considered by many to have

Top 5 Cable Tray Manufacturers in Australia

With the right manufacturer, businesses can ensure safe and effective cable management



that meets the unique demands of their projects.
The

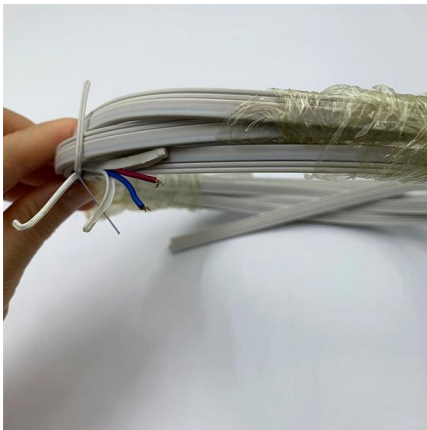

PRODUCT DATA SHEET 3 Core 3

All FireSense fire rated series cables are made from LSZH materials and have received third party PVC Free Certification from GECA (Good Environmental Choice Australia).

Cable Protection Solutions , Durable Fire Safety Systems

Fireproofing prevents the spread of fire through cable trays and conduits, maintaining critical systems such as alarms, lighting, and communication. By safeguarding

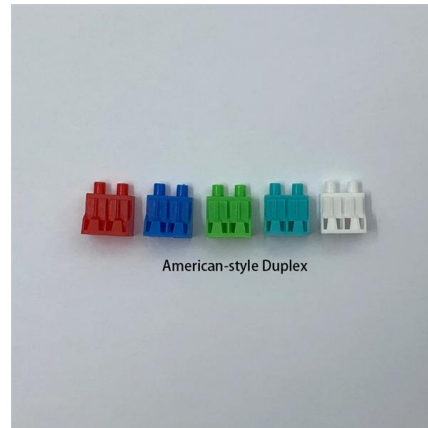

Fire-Resistant Cable Trays , Trafalgar Fire Products

Discover Trafalgar Fire's fire-resistant cable trays. Ensure safety and compliance with our top-quality fire protection solutions for cable management.



Fire Rated Cable Support Systems

The Kounis Group Fire Rated Cable Ladder Systems have been designed after extensive testing and fully comply with Standards Australia AS/NZS 3013:2005, Appendix C, Classification WS5X -- 2

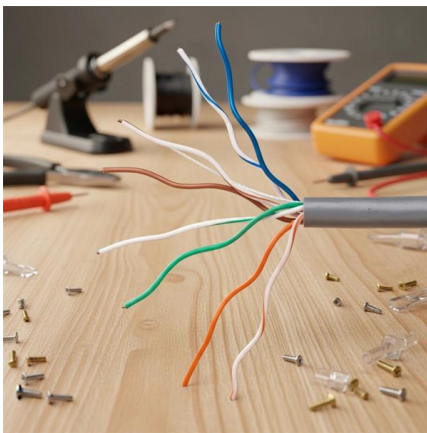

CABLE MANAGEMENT SYSTEMS

We offer a range of FRP or GRP Cable Management Systems including trays, ground ducts, ladders, accessories, supports, fittings, and fixings. These systems

Cable Tray Systems

Durable and reliable cable tray systems providing premium performance in commercial and industrial applications, available in a variety of materials to suit your needs.



What are the fireproof characteristics of cable trays?

Then, take the fireproof metal cable tray as an example to understand the fire protection requirements of the cable tray. Fire-resistant bridges are coated



AS/NZS3013:2005 FIRE RATED CABLE MANAGEMENT

All fire rated cable trays are supplied as trapeze kits with accessories necessary for installation to ensure compliance with AS/NZS3013:2005 (anchors and threaded rod are purchased separately).



Fire Rated Capabilities

The modular design integrates seamlessly into our cable support systems, enabling faster installation and long-term reliability. Choose Ozstrut to equip data centres,



Fire stop section of the cable tray and cable management NEMA

The following charts give the number of 3M pillows needed to completely firestop an opening that cable tray passes through.* Two (2) sticks of moldable putty (part number FSP-MPS) are also needed for



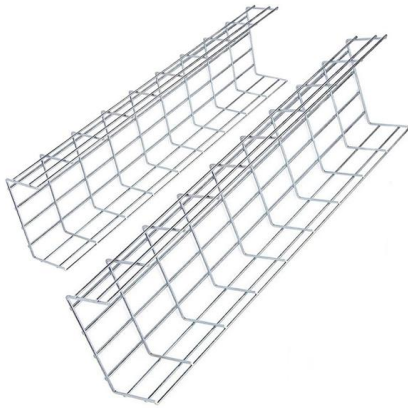

Fire protection for cables & cable trays , Flamro

Fire protection for cables and cable trays: effective solutions to prevent cable fires Cable systems are found in all buildings nowadays: from industrial plants via

Fire Protection of Cable Trays , Ceasefire PFP

Cable tray through fire rated wall The most common solution for the fire protection of cable trays penetrating walls is to wrap it with insulation on both

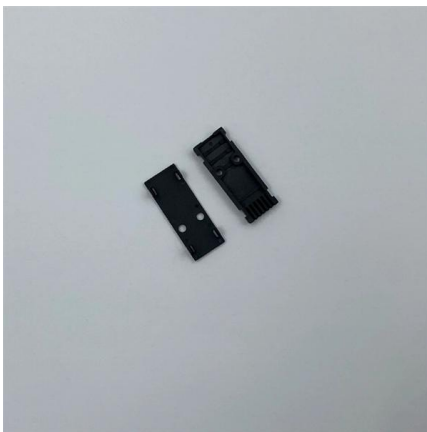

Fire Rated Cable Tray, Heavy-Duty Cable Tray Manufacturer

Fire Rated Cable Trays that are crafted from premium materials like stainless steel, galvanized steel, tempered glass, and fire-resistant polyester fiberglass. Each tray is coated with a specialized fire

Fire behaviour and construction safety precautions for

Cable tray type, ducts and conduits Although the type of cable and conductor is the determining factor in the fire behaviour of ducts and conduits, the

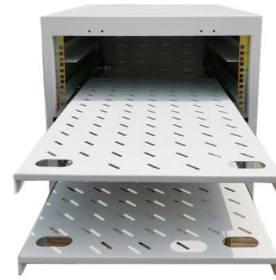

Cable Protection Solutions , Durable Fire Safety Systems

By safeguarding cables with our advanced fireproofing solutions, you enhance the resilience of your infrastructure, protect valuable assets, and ensure compliance

Top 5 Cable Tray Manufacturers in Australia

When selecting cable tray manufacturers in Australia, it is crucial to consider factors such as material quality, product versatility, ease of installation,



Cable Transits

Cable Transits consists of a square or round steel sleeve containing heat reactive intumescent polymer. Cables and pipes are placed inside the cable transit and



FyreWrap® Cable Insulation Wrap , Trafalgar Fire

Unifrax's FyreWrap® Cable Insulation is a thin, flexible, insulation wrap designed to provide a fire-protective enclosure around cable trays and conduit.



Contact Us

For datasheets, pricing, or custom telecom energy solutions, please visit:
<https://www.koskolong.co.za>